

# CARIBOL

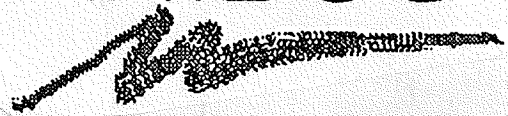

# LANCIA

Ricambi originali

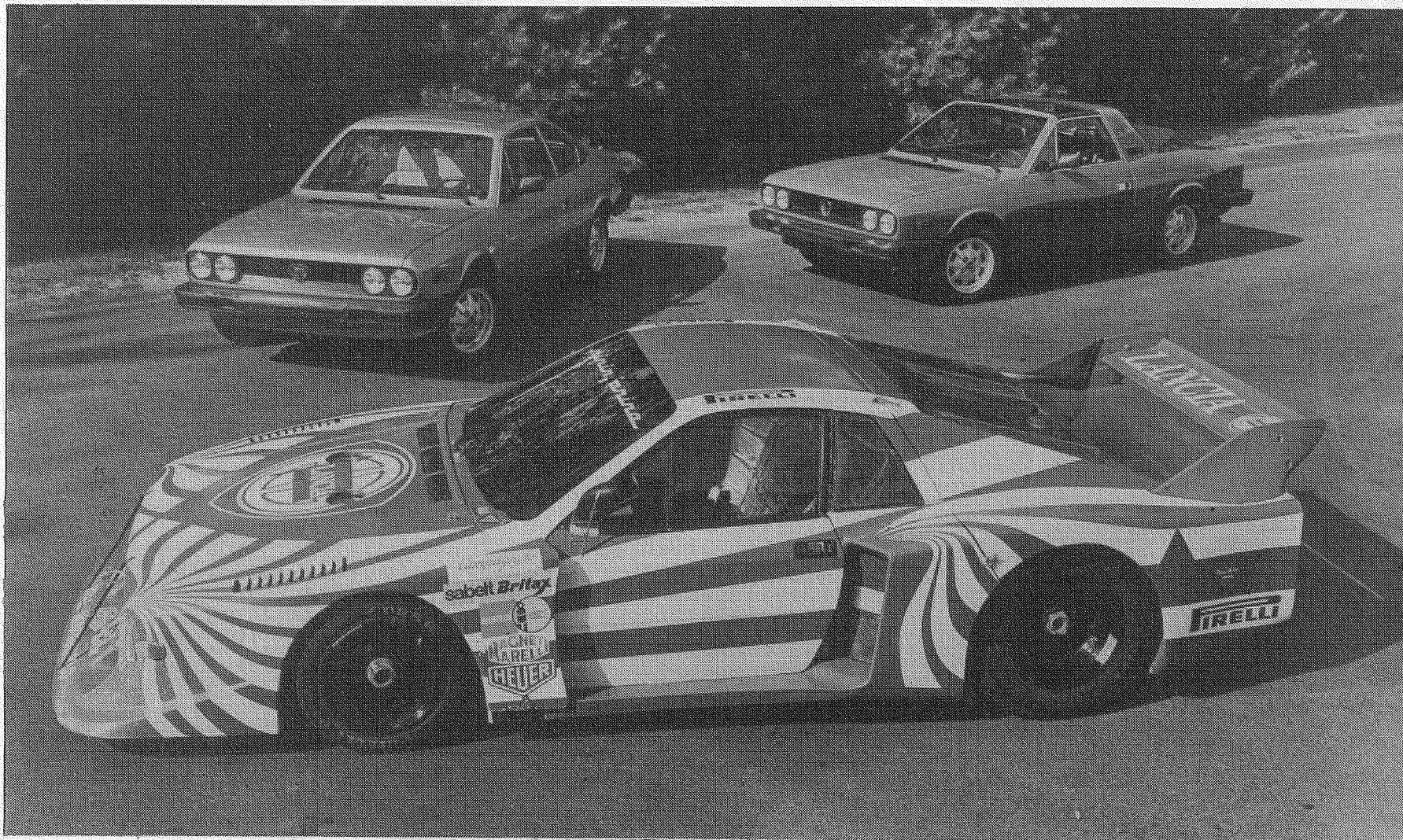

THE  
LANCIA  
PARTS  
SOURCE

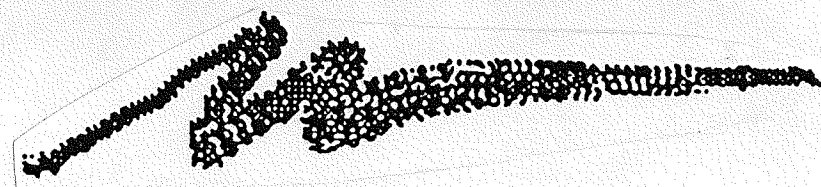

CATALOG #5.3

\$2.50

## CARIBOU IMPORTS, INC.

The Lancia Parts Source  
FIAT - Lancia Factory Authorized Parts Distributor  
Maserati Biturbo Parts & Accessories  
Specialists in Pre-Owned Sports & Import Automobiles  
23151 Alcalde Drive, Building A-3  
Laguna Hills, CA 92653-1419 USA  
TEL (714) 770-3136 FAX (714) 770-0815

Welcome to Caribou Imports, Inc. the *world-wide* parts source for Lancia automobiles. We thank you for your inquiry regarding our products. Our #1 job is the sale of parts and accessories for Lancia automobiles. Caribou Imports, Inc. has been providing Lancia owners with over 12 years of prompt, courteous and knowledgeable parts service. We are a *Factory Authorized Parts Distributor* and we receive shipments a minimum of twice a week directly from the factory! We augment those factory parts with many parts of our own manufacture and in many cases reproduce parts that the factory has discontinued.

This is our Lancia Parts Source Catalog #5.3. By referring to the appropriate page and part number on the enclosed pink catalog price list, you should be able to find the information you need on our various products. If you have any difficulty, please feel free to call, fax or write to us for any additional information.

Please remember, any catalog can only list a very small amount of the parts that we offer as we have *over 22,000 individual parts on our shelves!* To start taking advantage of our incredible stock of Lancia parts and our prompt world-wide shipping call or write to us today with your needs. We stock all Factory Original maintenance and tune-up items, interior & exterior body parts, crash repair, suspension, electrical, brake, engine parts,

transaxle parts and more...

*In short, if a part is glued, screwed or in any way attached to a Lancia and a human being can get it, this is where it comes from!*

Additionally, our stock of aftermarket parts and performance accessories is tremendous! We offer KONI shocks & struts, ANSA exhaust systems, RED LINE synthetic lubricants, LUBROMOLY chemical additives, PERFORMANCE camshafts, BORGIO high-compression pistons, HELLA lighting, DEVES piston rings, CUSTOM-FIT car covers and much more.

Nowhere on Earth is there a larger selection of literature for Lancias than at Caribou! Our Complete Catalog of Books, Shop Manuals and Technical Publications lists more than 70 publications, nearly 50 of them devoted exclusively to Lancia applications!

Over 90% of the phone and mail orders we receive by 2 PM are shipped *the very same day!* We accept MasterCard, VISA & C.O.D. orders and ship via UPS, UPS 2nd Day Air, UPS Next Day Air or truck. Need it quick? We'll get it there quick!

We are specialists in the export business. Caribou Imports ships all over the world! Our list of satisfied customers stretches from Japan, Canada,

England, France, Germany, Spain and even back to Italy! No matter where you are, Caribou Imports can handle your requests and ship our products without delay right to your door!

We accept Mastercard, Visa or COD orders for immediate world-wide same day shipping. If you have any questions or parts needs, please feel free to write or call us during our business hours (Monday-Friday 9:30 AM to 5 PM, Pacific Time). You may FAX us at our FAX number anytime which is open 24 hours a day, 365 days a year.

We hope to be able to serve you in the near future.

The Staff at Caribou Imports, Inc.

P.S. Caribou Imports, Inc. also carries as wide a selection of parts and accessories for all models of FIAT from 1967 and newer (especially 124/2000/ Pininfarina Spider and X1/9 Bertone models) along with Maserati Biturbos and Quattroportes! If you or an acquaintance owns any one of these cars, please remember us for any of your parts or accessories needs.

*OUR AUTOMOBILE SALES DIVISION BUYS & SELLS UNIQUE FIATS, LANCIAS AND OTHER SPORTS & IMPORT VEHICLES*



## A SERVICE FROM CARIBOU THAT ONLY WE COULD PROVIDE!

THE MOST COMMON QUESTIONS...  
HOW MANY WERE THERE?  
HOW MUCH DID THEY COST?

1975 PRODUCTION		
MODEL	# MADE	LIST PRICE
Coupe	722	\$7507
Sedan	1514	\$6232

1976 PRODUCTION		
MODEL	# MADE	LIST PRICE
Coupe	4335	\$7510
HPE	1199	\$8420
Sedan	1190	\$6560
Scorpion	1368	\$9943

1977 PRODUCTION		
MODEL	# MADE	LIST PRICE
Coupe	1756	\$7930
HPE	504	\$8995
Sedan	1899	\$6995
Scorpion	438	\$9995

1978 PRODUCTION		
MODEL	# MADE	LIST PRICE
Coupe	746	\$8803
HPE	81	\$9868
Sedan	398	\$8217
Zagato	4	test cars

1979 PRODUCTION		
MODEL	# MADE	LIST PRICE
Coupe	1486	\$9500
HPE	152	\$9985
Sedan	310	\$8551
Zagato *	1862	\$10,811

\* includes 500 Limited Edition Black & Gold cars

### 1980 PRODUCTION

There were no 1980 model cars imported. 1980 was used to clear out remaining stocks of leftover 1979 cars before introducing the 1981 models.

1981 PRODUCTION		
MODEL	# MADE	LIST PRICE
Coupe	970	\$10,574
Zagato	1618	\$12,593

1982 PRODUCTION		
MODEL	# MADE	LIST PRICE
Zagato	791	\$13,096

TOTAL NORTH AMERICAN IMPORTATION  
1975-1982 ALL MODELS: 23,343

**A NOTE REGARDING PRODUCTION FIGURES**  
The factory has never released specific production figures. The above numbers are Caribou Imports best estimates taking into account known chassis numbers at the beginning of model years, specific car chassis numbers and those car's production dates, along with information as to the approximate sum total of a particular model's production.

In some cases it is possible to isolate a certain model's production exactly due to it's unique combination of variables. In this case the production figures quoted are done so with virtually 100% accuracy. This is true for the following:  
1975 Sedan                      1976 Scorpion  
1977 Scorpion                1978 Zagato  
1979 HPE                      1979 Sedan  
1982 Zagato

If you have any additional specific information that may assist us in refining the accuracy of these figures, we would appreciate your input.

### A NOTE REGARDING LIST PRICES

All prices presented are that year's suggested list price for the "base" car. This price does not include options (such as air conditioning, power windows, power steering, metallic paint, leather upholstery, etc.) or transportation or dealer preparation charges. In most cases when sold,

Lancias were equipped with some "extra cost" options thereby raising the "sticker" price.

As an example, a 1976 Scorpion with air conditioning, metallic paint, power windows and leather upholstery had a "sticker" price of \$11,507.20

A 1977 Scorpion with just air conditioning and metallic paint had a "sticker" price of \$11,014.20



### SPECIFICATIONS

#### 1975 to 1978

All models used a 1756cc, twin-cam, single Weber carburetor engine and had a 5-speed manual gearbox. Horsepower ratings for the various models as follows:

Coupe, HPE and Sedan:  
49 State version                      86 hp  
California version                      83 hp

Scorpion, all                                      81 hp  
All Scorpions were built to California specifications, there were no "49 state" Scorpions.

#### 1979

All models used a 1995cc, twin-cam, single Weber carburetor engine. Most cars were equipped with the 5-speed manual gearbox, but a 3-speed automatic was available as an option in 1979 only. Horsepower ratings for various models as follows:

Coupe, HPE, Sedan and Zagato:  
49 State version                      87 hp  
California version                      83 hp

#### 1981-1982

All models used a 1995cc, twin-cam engine with a Bosch fuel-injection system. All were equipped with the 5-speed manual gearbox. The Coupe and Zagato were both available in 1981, only the Zagato in 1982. All cars were "50 state" versions.  
All models                                      106.5 hp

WWW.ITALIANCARMANUALS.COM



## THE CORRECT LUBRICANTS... ONLY CARIBOU KNOWS ENOUGH TO PROVIDE WHAT IS REQUIRED BY YOUR CAR!

### IMPORTANT TRANSMISSION SERVICE INFORMATION

Virtually every Lancia and Fiat on the road is long overdue for a change of transmission oil. The factory recommends a change every 18,000 miles and we recommend a change immediately after you purchase a used car - there's no telling how long it's been in there! PLUS: A majority of cars are using the wrong type of lubricant! That's right, almost everyone we talk to has been using conventional hypoid gear oil in the transmission. Wrong! Wrong! Wrong! Our transmissions contain no hypoid gears and regular hypoid gear oil (labeled "EP" for extreme pressure or GL-5 or GL-6) is actually detrimental to our cars! Quoted from the Fiat Spider Factory Shop Manual: "do not use EP (hypoid) oil."

*A majority of cars are using the wrong type of lubricant!*

Repeat... do not! GL-5 or GL-6 hypoid oils have a chemical additive package that leaves a film on transmission synchronizers; the additives actually lubricate the synchros too well and prevent them from functioning correctly! Use of this incorrect oil often shows up as minor grinding of the gears and difficulty in shifting; both problems especially evident going into second gear and in the first few miles of driving with a cold car. Continued driving with such problems can lead to expensive repairs in the future. Just think how much it will cost to drop a transmission from a car, then open it up and perform repairs. But, ever try to find the correct type of lubricant in an auto parts store? It's just not available!

*the Factory Shop Manual says: "do not use EP (hypoid) oil."*

Well, Caribou has what you are looking for! That's right, Red Line's Synthetic MTL (Manual Transmission Lubricant) is specifically designed for use in manual transmissions and transaxles... that is MTL's only application! MTL allows easier and

smoother shifting, plus it protects transmission gears and synchronizers from the chemical decay caused by GL-5 and GL-6 oils. We can't say enough about MTL... it's as close to "transmission rebuild in a can" as you'll ever find! We've seen it cure balky shifting problems that have gone on for years! MTL is perfect for all front engined Lancias and Fiats along with the mid-engine Scorpion and Fiat X1/9.

Do your Lancia or Fiat a big favor by following the recommended service intervals and change the transmission oil with the *right* oil... Red Line MTL.

#### RED LINE MTL (sold per quart)

Model	Capacity
Lancia 1975-1982 all 5-speed	2.6 qts
Fiat X1/9 4-speed	1.7 qts
Fiat X1/9 5-speed	3.2 qts
Fiat 124/2000 Spider 5-speed	1.75 qts
Fiat 131/Brava 5-speed	1.75 qts

### IMPORTANT CONSTANT VELOCITY (CV) JOINT SERVICE INFORMATION

If you've heard a rhythmic clicking sound when accelerating away from a stop, that's usually the sound of a CV joint going bad. Take a look for a torn boot, change it now and you'll possibly save the expense of a new joint. Just a few miles are needed to ruin a CV joint if a torn boot lets the lubricant escape and allows water, dirt and grime to enter. Changing a boot or a joint is an easy job and Caribou Imports can provide all the necessary parts in our CV Joint or Boot Kits, but have you ever tried to find CV joint grease? CV joints have extremely high load carrying capacity and need a special lubricant. Do not use wheel bearing grease! It is not designed for such loads and will lead to premature failure of the CV joint. Red Line CV-2 Grease is made specifically for this application. It's synthetic

*Do not use wheel bearing grease! It will lead to premature failure!*

composition provides reduced internal friction and lowers operating temperatures. The load carrying capacity of CV-2 is far greater than conventional petroleum-based greases and it has excellent water washout resistance, anti-wear performance and an extreme high-temperature capacity. Plus: it's far better than normal any wheel bearing grease, so feel free to use it as a high performance grease for conventional wheel bearings or in any other application where you want the finest lubrication characteristics available! CV-2 comes in a 14 ounce tube.

#### RED LINE CV-2 (sold per tube)

### IMPORTANT FUEL SYSTEM MAINTENANCE INFORMATION

The #1 trouble with fuel injection systems is dirty and clogged injectors. Though many gasolines advertise injector cleanliness, General Motors performed a study with the results indicating that car owners encountered injector plugging with all major brands of gasoline. Hard starting, rough idle, poor mileage, sluggish response and lack of power and are all signs of this problem. SI-1 Fuel Injector Cleaner contains the most powerful high-temperature detergents available to clean fuel injectors. SI-1 can clean injectors back to nearly 100% efficiency with only one treatment! Cleaning injectors may raise fuel economy 12% or more, depending on their original condition. SI-1 has detergents and an upper cylinder head lubricant which cleans intake valves, emission control parts and combustion chamber deposits. SI-1 also removes water from the fuel thereby protecting fuel system components from rust. Though SI-1 is designed for fuel injected cars, *it can be used on carburetted cars with all of the same benefits!* The 16 ounce bottle will treat up to 25 gallons of gas.

*SI-1 can be used on carburetted cars with all of the same benefits!*

#### RED LINE SI-1 (sold per bottle)



# AT CARIBOU IMPORTS WE OFFER ONLY THE WORLD'S FINEST IN LUBRICANTS, ADDITIVES AND FLUIDS VITAL FOR OPTIMUM PERFORMANCE

## AGIP SINT 2000 SYNTHETIC MOTOR OIL

AGIP SINT 2000 is very likely the finest motor oil available! It's required in every new Ferrari to keep the car under warranty and is the only oil recommended by both Maserati and Alfa Romeo. AGIP has been producing synthetic oils for over 20 years and the legendary SINT 2000's lubricating & anti-wear properties are unsurpassed! This is the exact same oil poured directly into the engines of the Ferrari Formula 1 race cars! Give your car the same protection that is demanded by these mega-buck exotics. SINT 2000 10W-40 oil is sold per quart.



### VENTIL SAUBER (VALVE CLEANER)

Ever looked at the valves on an engine that's been disassembled? That hard, crusty black build-up is a result of today's high engine operating temperatures combined with fuel of "borderline" quality and torturous stop-and-go driving. Components in the fuel evaporate before entering the combustion chamber, leaving deposits behind that always build up on the intake valves. These deposits rob you of performance, cause drivability problems, lack of power and poor gas mileage. Ventil Sauber is simply added to a tank of gasoline and is specifically designed to remove the deposits on intake valves and clean the entire fuel system. It can also remove combustion chamber deposits thereby reducing your engine's octane requirements. Ventil Sauber is recommended by name by both Porsche and Mercedes. (5 oz. can)

### SAS ANTIFREEZE/COOLANT

SAS Coolant is specifically designed for compatibility with all types of metals, plastics and polymers, *plus:* it contains no phosphates or other chemicals which can promote corrosion and actually create

cooling system blockage over time. Other coolants which claim to be "safe for aluminum" are indeed safe for aluminum, but cannot make the claim of being phosphate-free and chemical-free to prevent aluminum corrosion and electrolysis! SAS Coolant will withstand high-temperature "torture" as encountered in water-cooled turbocharged engines. When used in a 50/50 mix with distilled water, it provides unparalleled protection and cooling efficiency in all types of engines. Sold per gallon container.



### OIL SLUDGE REMOVER (OIL CHANGE PREP)

No matter how frequently you change your oil, small capacity oil sumps combined with lean burning engines and stop-and-go traffic can result in sludge and varnish build-up inside your engine. Or have you just purchased a used car and have no idea how often the oil was changed and what quality oil was used? Sludge and varnish can block oil screens, filters and passages gumming up the engine and eventually causing expensive damage. Oil Sludge Remover (added to the engine oil shortly before an oil change) will loosen and dissolve sludge and varnish, then keep it in suspension to be drained away in the old oil. You will absolutely be amazed at the color and content of the "crud" that comes out! Your engine is now prepared for the fresh oil and proper lubrication is restored, with possible engine damage prevented. This product is highly recommended! (10 oz. can)

### RED LINE SYNTHETIC GEAR OIL

This 75W-90 oil provides the best protection and efficiency for rear axle differentials. It features tremendous thermal stability, the best film strength available and the ability to cope with high torque, high speed and high shock loads. It can provide a significant improvement in power transfer and fuel econ-

omy, while also maintaining a thicker oil film in the high-temperature gear tooth contact zone which improves drivetrain longevity. This is the best lubricant available for rear axles and differentials, especially the limited slip type. (sold per quart)

### AUTO ELECTRIC CARE

Blended with a special contact treatment oil and appropriate solvent, Auto Electric Care penetrates through accumulated layers of oxides and dirt to restore proper performance of electrical switches, ignition components, instrumentation, lighting, plug-in or fixed connections and terminals, lamp and fuse sockets, rheostats and dozens of other items. Do you have "sticky" or intermittent parts? Auto Electric Care may solve the problem. It lowers electrical resistance, stops current leaking and protects against abrasion, oxidation and contact deterioration. Unlike other similar products, it is safe to use on painted lacquer surfaces and rubber and plastics. It also does an excellent job on mechanical parts such as locks, levers, slides, antennas, etc. Sold per 3.3 ounce spray can.



### ANTI-SIEZE COMPOUND



Many threaded engine parts (like spark plugs, cylinder head and exhaust manifold bolts, muffler and exhaust nuts, turbo charger mounting hardware) will seize, gall or rust in place if assembled "dry". Dissimilar metals (like a steel stud in an aluminum head) will corrode together unless precautions are taken. Our copper-based Anti-Seize Compound will protect nuts and bolts from seizure, galling, rust and pitting. Basically... if you ever want to undo a threaded fastener at some time in the future, you better put some of this on it now! The 3.5 oz. tube will last a long, long time.

## THE RIGHT TOOLS TO MAKE THE JOB EASIER !

### VALVE SHIM DEPRESSOR

The only way to depress the valve shim "buckets" so you can change shims during valve adjustment. This is a factory supplied tool, made from heavy-duty steel for years of dependable service! Order Part #60594

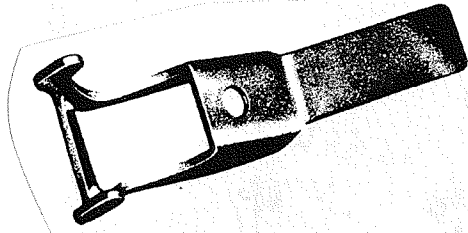

### HEX WRENCH FOR OIL PAN DRAIN PLUG REMOVAL

Only Lancias and Fiats use this size "hex head" plug on their oil pans, so you need this wrench to be able to unscrew it. This is the heavy-duty "service department" tool supplied by the factory, not some cheap "made who knows where" out of "who knows what"!

Order Part #50113



### CLUTCH ALIGNMENT TOOL

When replacing a clutch it is necessary to align the splines on the clutch disc so the input shaft of the transmission can pass it through when reassembling. Ask anyone who's tried to hold a 200 pound transmission up while trying to "stab" the input shaft through an un-aligned clutch assembly... no fun at all! Our alignment tool makes this job as easy as possible. Don't attempt a clutch job without it! Order Part #70081

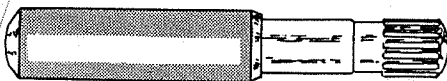

### SCORPION WHEEL BEARING "RING NUT" REMOVAL TOOL

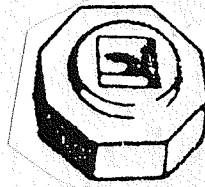

The front and rear wheel bearings on the Scorpion are retained by a large external thread "ring nut", so for changing wheel bearings on a Scorpion this tool is essential! There is absolutely no way to properly remove the old ring nut and replace it with a new one without using these special eight-sided removal/installation tools. The front and rear ring nuts are of different sizes on the Scorpion, so be certain to order the tool you need (or order both to do wheel bearings "all around").

Scorpion Front Bearing Ring Nut Tool:

Order Part #11748

Scorpion Rear Bearing Ring Nut Tool:

Order Part #11752

### 13mm "T" HANDLE OFFSET WRENCH

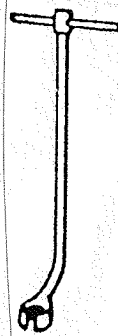

This is the factory original tool for tightening and loosening the air injector "nozzles" screwed into the cylinder head on 1975 to 1979 Lancia models. Those of you who've tried to do this job with a regular open end wrench can understand why the factory made a special tool to deal with this cramped and obstructed area. Besides its original intended use though, you'll find dozens of other applications for this handy little wrench: carburettor hold down nuts, distributor hold down nuts on some models, manifold nuts, etc. Think about it... your car is practically built with 13 millimeter nuts and bolts! A worthy addition to any toolbox! Order Part #4630

### CARIBOU IMPORTS FACTORY ORIGINAL TOOL KIT

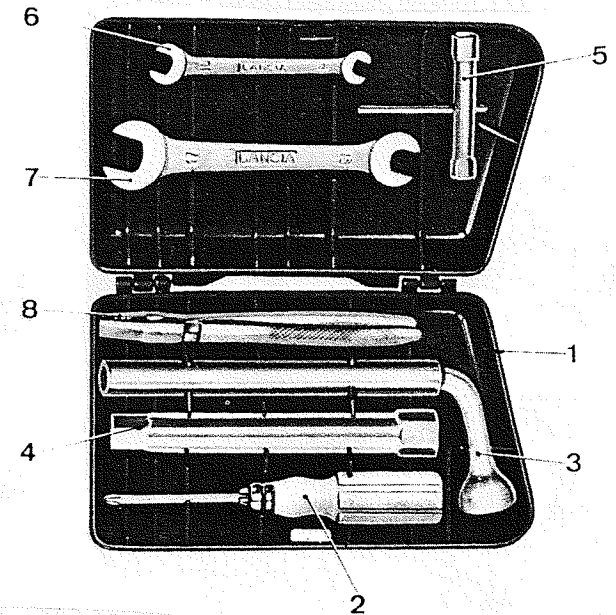

Every car sold by Lancia came with one of these very comprehensive kits in a very smart looking plastic case with the "LANCIA" name embossed in. Included in the kit are:

- 1) "LANCIA" tool case
- 2) Reversible phillips/flat blade screwdriver
- 3) Lug nut wrench/"cheater" bar
- 4) Spark plug removal wrench
- 5) 8mm x 10mm "T" type wrench
- 6) 8mm x 10mm open end wrench
- 7) 13mm x 17mm open end wrench
- 8) Pliers

Most of these kits by now are lost, broken or missing tools but now you are able to replace this very rare item with a complete new kit! Ensure your roadside ability to make minor repairs or for those of you requiring the highest degree of accuracy in a concours restoration, nothing can top this! Order Part #17867

# CARIBOU

UNLEASH SOME  
ITALIAN HORSEPOWER...  
With Performance Enhancements  
from Caribou Imports

**ANSA MUFFLERS...  
THE MUFFLER THAT  
FERRARI FITS**

Your Lancia's engine has to breathe. The combined action of inhaling and exhaling is of crucial importance to the operational cycle of the engine. The factory exhausts do a credible job of maintaining acceptable noise levels; however, in a majority of cases, exhaust restriction is a major negative side effect.

In the pursuit of increased performance and improved fuel economy, you should consider the exhaust system as your first area of modification. A typical ANSA system will yield extra horsepower, raise fuel economy and lower the engine's operating temperature. ANSA Free Flow exhaust systems are designed to maintain acceptable noise levels without restricting the flow of exhaust gases. The tuned tubular headers scavenge the exhaust gases by using the velocity of each cylinder's exhaust flow to assist the flow of the other cylinders. The combination of dual perforated pipes in the mufflers surrounded by fiberglass achieves the same sound-deadening qualities as the original mufflers without creating restrictive back pressure.

ANSA Free-Flow exhaust systems are constructed of the finest 16-gauge reinforced steel with custom welded seams. Each system is protected by a wrinkle-finish black corrosion-resistant coating and all tips are triple-coated chrome for beauty and longevity.

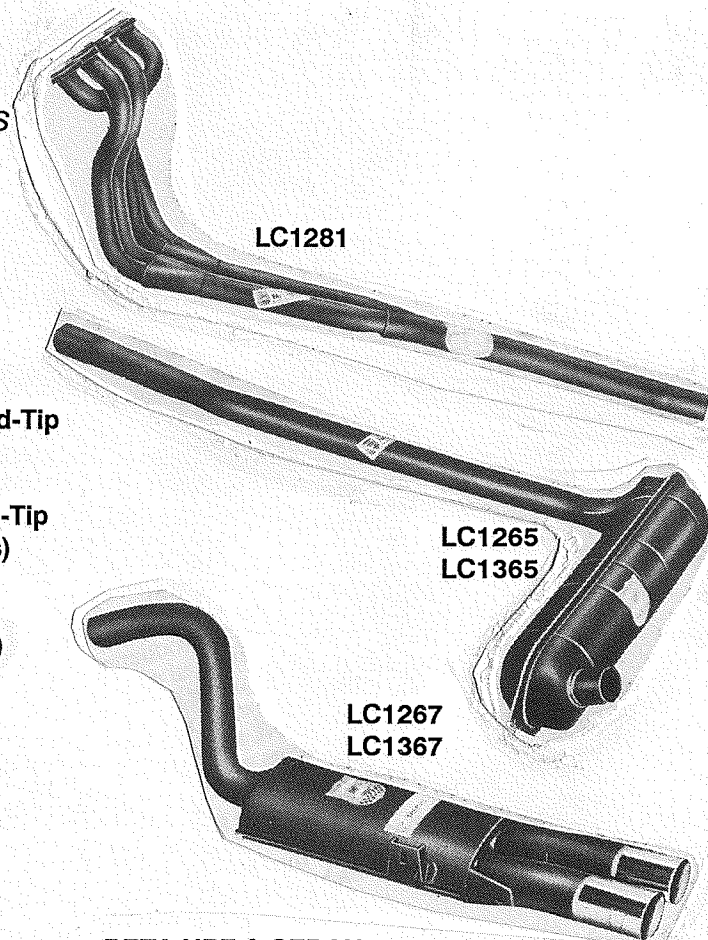
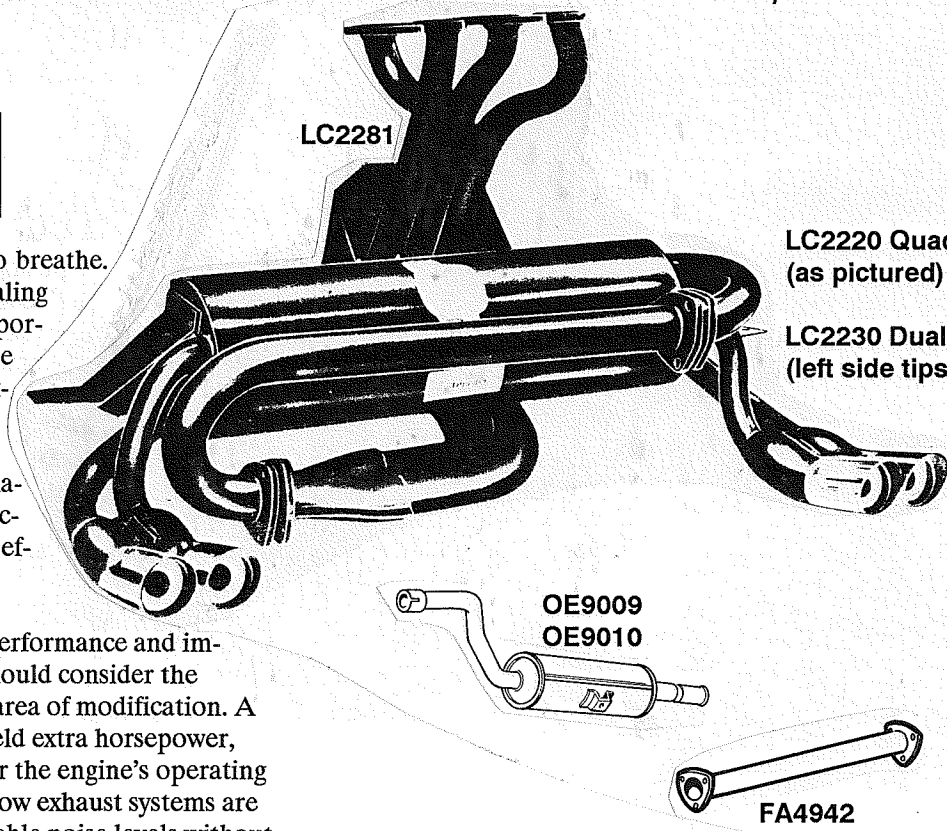

## SCORPION & MONTECARLO

Racing Header & Heat Shield <sup>AB</sup> LC2281  
Quad-Tip Muffler & Inter Pipe <sup>B</sup> LC2220  
(Dual Tips on both sides)

Racing Header & Heat Shield <sup>AB</sup> LC2281  
Dual-Tip Muffler & Inter Pipe <sup>B</sup> LC2230  
(Left side tips only)

## BETA COUPE & ZAGATO

Racing Header <sup>AC</sup> LC1281  
Center Muffler LC1365  
Rear Muffler (1975-1978) LC1367  
Rear Muffler (1979-1982) <sup>D</sup> OE9010

## BETA HPE & SEDAN

Racing Header <sup>A</sup> LC1281  
Center Muffler LC1265  
Rear Muffler (1975-1978) LC1267  
Rear Muffler (1979) <sup>D</sup> OE9009

## ALL MODELS WITH 3-BOLT CONVERTOR

Catalytic Convertor "Test" Pipe <sup>A</sup> FA-4942

### NOTES:

- (A) Legal in California *only* on racing vehicles which may *never* be used upon a highway.
- (B) Must be used together as a complete system.
- (C) Has no provision for Lambda sensor used on fuel injected cars, minor modifications are necessary.
- (D) ANSA Free Flow rear mufflers do not fit under the rear valence panels of 1979 and later models. These ANSA original equipment replacement mufflers must be used. These ANSA mufflers will fit onto the stock exhaust system also.



# PERFORMANCE CONVERSIONS FOR LANCIA SCORPION, COUPE, HPE, SEDAN & ZAGATO

Unleash some Italian horsepower and put a smile on your face!

## PERFORMANCE CAMSHAFTS FOR LANCIA & FIAT TWIN CAM ENGINES

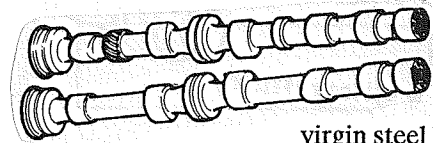

We are very pleased to offer our Performance Cams cut from virgin steel billets. With 40-

80/80-40 valve timing (300 degrees duration) and 10.35 mm of valve lift, these cams are the biggest improvement you can make to your engine! The stock cam timing from the factory was 5-35/35-5 setting engine tuning and performance backwards 50 years! Your engine in stock form is literally wheezing to get enough air/fuel mixture to perform. Our Performance Cams are computer ground in Italy by specialists who also produce cams for Ferrari and Lamborghini.

They work very well with the stock carburetor re-jetted, our 34mm Weber conversion or other single or dual carburetor conversions.

*"it feels as if you're driving a V-6 instead of a 4"*

An important note to owners of fuel-injected models is that they will require no modifications at all for maximum performance. The Bosch L-Jetronic system will compensate for the additional air flow and a properly functioning Lambda (oxygen) Sensor will adjust for proper air/fuel mixture providing literally bolt-on horsepower! Our Performance Cams feature excellent power from low-end torque through the midrange, where it feels as if you're driving a V-6 instead of a 4, and provide an fabulous pull all the way up to redline. These cams do not have the air pump drive pulley extension and are legal in California *only* on racing vehicles which may *never* be used upon a highway.

PART#	APPLICATION
C240	1975 thru 1979 Coupe, HPE, Sedan, Zagato and all Fiat 124 and 131/Brava
C241	1981 & 1982 fuel injected Lancias
C242	Scorpion & MonteCarlo, all

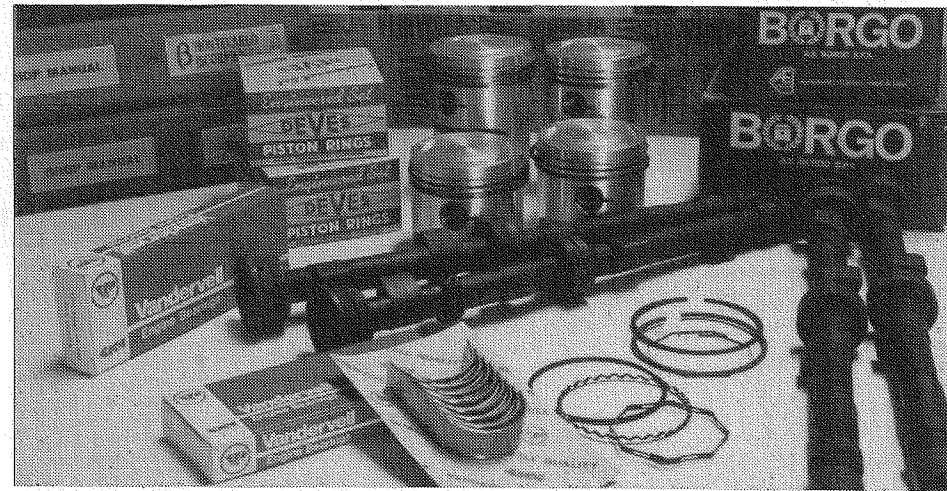

## PISTONI SPECIALI BORGIO HIGH COMPRESSION EUROPEAN PISTONS

The European 9:1 compression ratio pistons for both 1800 cc and 2000 cc twin-cam engines are here! Now you can unlock the "free horsepower" in your engine that raising the compression ratio allows. 9:1 pistons provide a significant torque and power boost and do not require special attention to fuel quality and octane rating. Compression ratios any higher than this will need special fuels or additives or force you to retard the ignition timing to avoid dangerous "pinging". Special fuels or additives are extremely inconvenient and expensive while retarding ignition timing just takes away what power you supposedly gained by the much higher compression ratio anyway. Our recommendation for across the board enjoyable performance is 9:1. Our piston sets are manufactured by Pistoni Borgo S.P.A. in Italy as a complete set of four including piston rings, wrist pins and retainer clips. These piston sets are available in the standard size of 84 millimeters and the oversize of 84.4 millimeters. Now there is no reason to use anything but the best in your engine rebuild!

For those of you wishing to maintain the strictest degree of authenticity with your Lancia, we also have

the factory original piston sets with a compression ratio of 8:1 available in 84 millimeters, 84.4 millimeters and 84.8 millimeters. These sets are also complete with piston rings, wrist pins and retainer clips.

When ordering please specify high-compression (HC) or stock compression (Stock) and the size of pistons desired. The high compression pistons are legal in California *only* on racing vehicles which may *never* be used upon a highway.

## WEBER/CARIBOU 34MM PERFORMANCE CARBURETOR

Our 34mm Weber Carburetor features barrels 2 millimeters larger than stock for more power while still retaining good gas mileage. Cure poor starting, rough running and lack of power in one bold stroke! Features cable operated manual choke and will retain your stock air cleaner. This is a bolt-on conversion and fits all the 1975-1978 Coupe, HPE, Scorpion and Sedan models. This carburetor is legal in California *only* on racing vehicles which may *never* be used upon a highway.

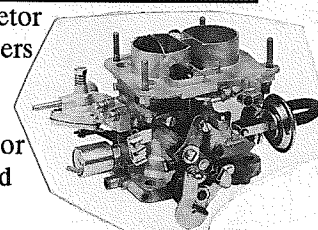

34mm Weber Carburetor

## ONLY THE BEST PARTS TO GO UNDER YOUR HOOD!

### DEVES PISTON RINGS

Deves Swedish Steel Piston Rings are highly recommended as the best piston ring set to use for the finest engine rebuild! Deves Rings provide maximum sealing at high revs for top performance, yet by the use of a unique, exclusive, expander oil control ring, Deves Rings will also reduce oil consumption.

They have greater flexibility and will wear longer while preventing excessive oil consumption and providing maximum compression. Available for the following models in a complete set for 4 pistons. When ordering, please specify part number and size (standard or over-size of .020, .030 or .040 inch).

<u>MODEL</u>	<u>PART #</u>
All Lancia, 1756cc & 2000cc	1939
All Fiat X1/9 & 128, 1290 cc	1924
All Fiat X1/9 & 128, 1500cc	2101
Fiat 124, 1438cc & 1608cc	1862
Fiat 124 & 131, 1756cc & 2000cc	1939
Fiat 850	Please inquire

### ENGINE BEARINGS

Don't settle for less than the best! Our Factory Original engine bearings guarantee low friction, long life and most importantly a perfect fit! Available in complete sets of standard or oversizes in .010, .020 or .030 inch sizes. Please specify part number and size.

<u>All 2000cc and Scorpion:</u>	<u>PART #</u>
Main bearing set	10.880256
Connecting rod bearing set	10.951741
<u>All 1756cc (except Scorpion):</u>	<u>PART #</u>
Main bearing set	10.880256
Connecting rod bearing set	10.951741 <u>or</u> 10.951685

(For 1756cc, note rod bearing oil holes as shown.)

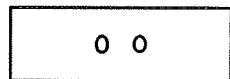

10.951741  
(centered holes)

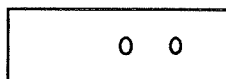

10.951685  
(offset holes)

<u>All Years, All Models:</u>	<u>PART #</u>
Pre-sized auxiliary shaft bearings (sold as a pair, standard size only)	12.0989

### GASKET SETS

Our Lancia Original Equipment gasket sets include everything needed for cylinder head work or to rebuild your entire engine. Included are: each and every gasket, camshaft & auxiliary shaft & crankshaft oil seals, oil cap seal, O-rings, valve guide seals and much more! Everything you need to do the job correctly the first time is here! Beware of the "one-set-fits-all models"... because they don't!

<u>MODEL</u>	<u>DESCRIPTION</u>	<u>PART #</u>
76-77 Scorpion	Head Set	1489
	Complete Set	1490
75-78 1756cc (except Scorpion)	Head Set	1485
	Complete Set	1486
79 All Models	Head Set	1505
	Complete Set	1506
81-82 All Models	Head Set	1529
	Complete Set	1531

The Lancia Beta 5-Speed Transaxle Gasket Set (*a CARIBOU EXCLUSIVE!*) contains all the gaskets, seals, washers, O-rings, etc. necessary for doing repair work on your Lancia's 5-speed transaxle. This set is not available anywhere else!  
All Years, All Models Transaxle Set 1601

### WEBER ORIGINAL EQUIPMENT CARBURETOR REPAIR KITS

TUNE-UP KITS contain gasket sets, needle and seat, float, O-rings, seals and any other parts necessary for basic carburetor service.

MASTER REPAIR KITS contain all Tune-Up Kit parts plus: diaphragms, main & air corrector jets, throttle shafts, ball bearings (if required), throttle plates, screws and any other additional parts required to perform a major carburetor rebuild.

<u>WEBER TUNE-UP KITS</u>	<u>PART #</u>
1975-1978 all models	1176
1979 all models	1285
<u>WEBER MASTER REPAIR KITS</u>	<u>PART #</u>
For 49 State Models (except Scorpion)	
1975 Coupe & Sedan	2247
1976 & 1977 Coupe, HPE & Sedan	2323

1978 Coupe, HPE & Sedan	2427
1979 models, manual transmission	2475
1979 models, automatic trans.	2413

For California Models (except Scorpion)

1976 & 1977 Coupe, HPE & Sedan	2268
1978 Coupe, HPE & Sedan	2429
1979 models, manual transmission	2476
1979 models, automatic trans.	2413

For Scorpion Only

1976 & 1977 models	2268
--------------------	------

### STANDARD TIMING BELT

This is the factory original timing belt as used on all Lancia and Fiat twin or single cam engines. The factory recommends replacing your timing belt every 25,000 miles and be certain to never, never reuse a belt that's been removed from an engine. Belts are available for 1300, 1438, 1500, 1592, 1608, 1756 or 2000cc engines. Specify year, model and engine size.

### CARIBOU IMPORTS EXTRA-WIDE TIMING BELT

If you require the highest degree of security for your twin-cam engine, consider our "Extra-Wide" Timing Belt.

Made in Italy by Pirelli, this is the same belt used on factory rally cars; it's 2mm wider than a stock belt for extra security at high revs. We especially recommend an "Extra-Wide" Belt for high performance engines, particularly those with high lift camshafts as these cams do place a greater strain on the timing belt.

If you are planning to change your timing belt for regular maintenance or during an engine rebuild that you are planning, definitely buy an "Extra-Wide" Belt now so it will be readily available when you need it. Also, since the "Extra-Wide" Belts are always subject to sporadic supply, why not think about buying a spare one now to save for future use?

EXTRA-WIDE TIMING BELT for 1756cc or 2000cc (available only for above engines, please specify)

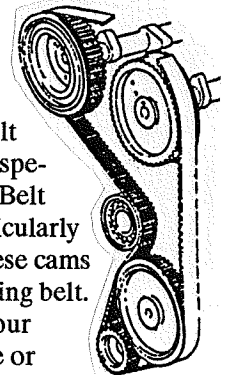

## KONI SHOCKS AND STRUT ASSEMBLIES

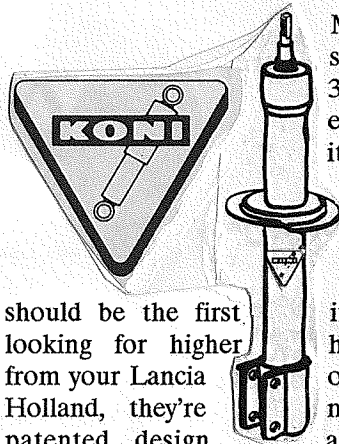

should be the first looking for higher from your Lancia Holland, they're patented design

Most original shocks and struts are worn out by 30,000 miles leading to excessively soft ride quality, lack of handling and poor car control.

KONI struts and shock absorbers are the world's finest and item on your list when handling capabilities or Fiat. Originated in made from a special and custom-engineered

to the specific Lancia or Fiat application. Each Koni carries a manufacturer's lifetime warranty and can be set to your driving style and readjusted time and again, so they last longer than ordinary shocks. Koni durability and handling are legendary and these qualities make

them the best shocks in the long run. Race bred, Koni has an impressive record,

including over 135 Formula 1 Grand Prix winners over the last decade and 10 straight World Championships. Both Ferrari and Porsche, among others, think enough of their customers to install Koni struts and shock absorbers as Factory Original Equipment. Follow the lead of the winners and install KONIS on your car!

Koni construction is superb! The super rugged; induction-hardened steel piston rod has been chrome plated to an ultra-hard finish. All moving parts are machined from solid stock. The piston rod guide is machined from special material to insure low friction and minimum wear. Consistently close clearances of piston to cylinder assembly insure trouble-free performance. To guarantee precision roundness and strength, the inner cylinder is drawn from seamless

*"Looking for increased handling and cornering capabilities from your Lancia or Fiat?"*

tubing. Rebound forces are controlled by unique system of orifices and spring-loaded by-pass valves so there is no need to depend on oil viscosity! All KONIS for Lancias come as a full strut assembly. Just remove the existing strut from your car, remove the top spring mount and the spring, install them on the new Koni Strut Assembly and replace. Simple!

MODEL	FRONT	REAR
1975-1982 Coupe & Zagato	87-2119	87-2120
1976-1979 HPE	87-2119	87-2118
1975-1979 Sedan	87-2117	87-2118
All Scorpion & MonteCarlo	87-2121	87-2122

Please inquire for any FIAT applications.

## STAINLESS STEEL BRAIDED BRAKE LINES

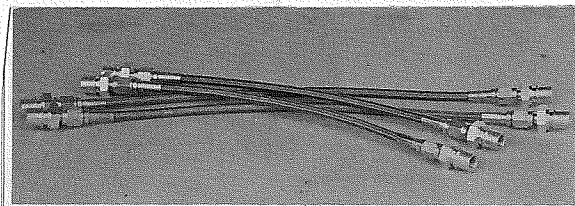

Have you checked the condition of your Scorpion's brake hoses lately? Most we see are rotted and cracked, especially where the rubber hose meets the metal "banjo" connector bolted to the brake caliper. But besides old age, poor brake pedal feel is a common problem not only high-performance Scorpions driven enthusiastically but with those cars that are driven very conservatively. Now you can have confidence in your stopping ability and combat spongy brake pedals with our Stainless Steel Brake Line Kit. The braided stainless steel cover resists abrasion and corrosion while the inner Teflon tube is extremely resistant to expansion under pressure and is compatible with all brake fluids. Our kit provides consistent brake pedal pressure for positive, firm braking under all conditions and helps resist water contamination of your brake fluid too! Our kit is 100% complete with all necessary adaptors, sealing washers and stainless steel braided brake lines.

Scorpion Braided Steel Brake Line Kit #1.2777

## SCORPION GEARSHIFT BUSHING KIT

Is sloppy shifting or missed gears a problem with your Scorpion? When new, Scorpions always had very crisp and accurate shifting, but over the years this can degrade to an alarming extent. Each end of the shift linkage rods and the main support shaft in the engine compartment has a "silent block" bushing (seven in total) which deteriorates, splits open and finally can fall out thus stranding you by preventing gear selection completely! Take a look and you'll probably find the cracked or broken remains where your bushings used to be. Caribou's exclusive Gearshift Bushing Kit (available nowhere else) has all the parts you need to return your shifting to "crisp as new" condition.

Scorpion Shift Bushing Kit #8.304090

## MODIFIED SCORPION CROSSMEMBER

**WARNING:** We recommend all Scorpion owners check their chassis crossmember; this is the steel box-section piece just forward of and below the engine. It's bolted to both sides of the car and supports: front mounting point of the control-arms, front mounting of the anti-sway bar, front engine/gearbox mount and handbrake cable. This is the "heart" of the entire rear structure of the Scorpion! Many of these crossmembers have both minor and major cracks completely through! Usually the crack is on either side of the mounting plate for the handbrake cable, although we have seen cracks at the outer mount for the control arm. Please check yours today, especially if you've experienced popping out of gears, difficulty in rear wheel alignment, or a "wandering" feel at highway speeds or during cornering. We provide a Modified Crossmember which has been checked for alignment and has reinforcing plates welded on to withstand all stresses. Our Modified Crossmembers are available only on an exchange basis, so please inquire for the specific details on this program. But please do not delay, as we have seen diastereous results from neglect!

*"Many of these crossmembers have both minor and major cracks completely through!"*



## MORE GOODIES FOR LANCIA SCORPION, COUPE, HPE, SEDAN & ZAGATO

### OUR EXCLUSIVE CARIBOU/K&N FREE-FLOW AIR CLEANER

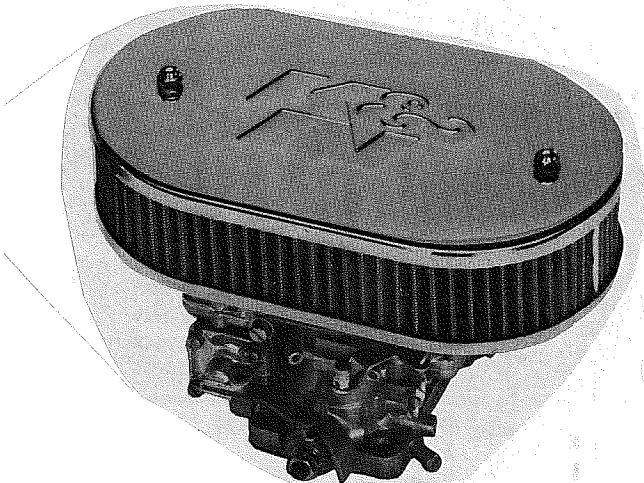

the filter element. K&N in fact, recommends cleaning at 50,000 mile intervals... talk about long life! The PVC hose connection is a 1/2 inch pipe fitting screwed securely to the base of the air filter (not the cheap, flimsy metal bracket arrangement held between the top and bottom covers on the Brand "X" filter) ensuring that no oil leaks will occur.

Besides all these performance advantages, our Free-Flow Air Filter plain and simple just looks great! Imagine how good your engine compartment will look with that show-quality chrome finish sitting atop your carburettor! Caribou's Free-Flow Air Cleaner fits all 1975 through 1979 Lancias (including the Scorpion) without modifications; it does not fit fuel injected cars.

CARIBOU/K&N FREE-FLOW AIR FILTER \*  
PART NUMBER 101859

### ALLSION PERMA-SPARK CUSTOM-FIT SILICONE IGNITION WIRE SET

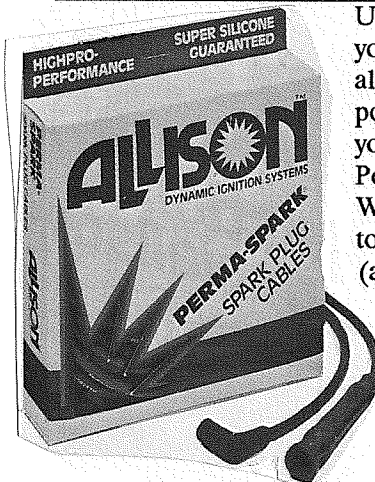

Unleash the full power of your Lancia's engine by allowing the strongest possible spark to reach your plugs! Caribou's Perma-Spark Ignition Wire Set is custom made to our high standards (and exclusively for us)

by Allison to ensure a perfect fit under your hood! Constructed of a blue, thick super silicone outer jacket and a nylon-fiberglass

high-strength inner core which is specially woven around the insulation layer, our Perma-Spark Ignition Wire Set allows maximum flexibility without stretching or breaking. When installed along with our Chrome Free-Flow Air Cleaner (listed above) it's an unbeatable combination!

PART#     APPLICATION  
250-1101   fits all 1975-1978 models including:  
Scorpion, Coupe, HPE & Sedan

### ELECTRONIC SOLID STATE FUEL PUMP

100% solid state for 100% reliability! Compact, lightweight and easy to install, this 12-volt pump puts out a high capacity of up to 35 gallons per hour at 4 p.s.i. It's excellent for all stock, replacement or performance Weber carburetors.

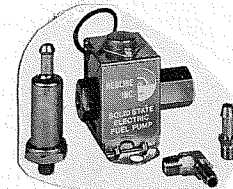

SOLID STATE FUEL PUMP  
#19898

### DOOR AND IGNITION KEYS



ALL MODELS IGNITION KEY BLANK  
All the 1975-1982 Lancia models use the same ignition key blank. Just order as many as you need and have your local locksmith cut the blanks for you.

IGNITION BLANK #2757

### SCORPION DOOR OR GAS CAP BLANK

The Scorpion used three different blanks which are not interchangeable. To provide you with the correct blank, we must have the first number of the key code stamped on your existing door key. This will be either 1, 3 or 5. The Factory Original locking gas cap uses the same style blanks as the door. If it's key is not the same as your door key and you need a gas cap key, please provide the code number if different.

DOOR OR GAS CAP BLANK #1, 3 or 5

### COUPE, HPE, SEDAN & ZAGATO DOOR KEY

The door key for Betas is unlike anything else ever produced and is cut to your lock code by computer at the factory. The "holes" or "swipes" that you see taken out of the key blank represent the positions and depths that the 4-digit code tells the computer.

To provide you with new door keys, we must have the 4-digit key code from your existing door key so the factory can computer-cut a new key for you. Please note: if you have purchased a car without door keys or have lost your own door key that had the code don't despair... please call us for additional information on how to obtain new keys.

BETA DOOR KEY #0758-\_\_\_\_ (4-digit code)

For years now, our customers have been requesting a performance air filter to compliment their Lancias but there's never been one good enough for our high quality standards. We've refused to handle the "junk" that's available... you know the ones with gooey foam elements held together by 4 cheap little metal clips (and don't you know each one of those clips is just waiting to fall off and lodge in your timing belt with disasterous results!).

Well, our great looking and performing Caribou Free-Flow Air Filter is certainly good enough for us to stand behind! This filter is made in the USA exclusively for us by K&N, the world leader in air filter technology and are of the highest quality. Our Free-Flow Air Filter is oval shaped, 9 inches long by 5.5 inches wide and 1.75 inches high with show-quality chrome plated top and base bolted (yes bolted, not clipped) together. The filter element is one of K&N's famous Hi-Flow Washable Air Filters (not junky, gooey foam). These elements are recognized as the world's best air filter featuring a special design cotton fabric utilizing K&N's oil suspension system to trap and hold minute dust and dirt particles. This cotton fabric is in an accordion design reinforced by an aluminum screen mesh providing unmatched durability of

# LANCIA SCORPION and MONTECARLO BODY & TRIM

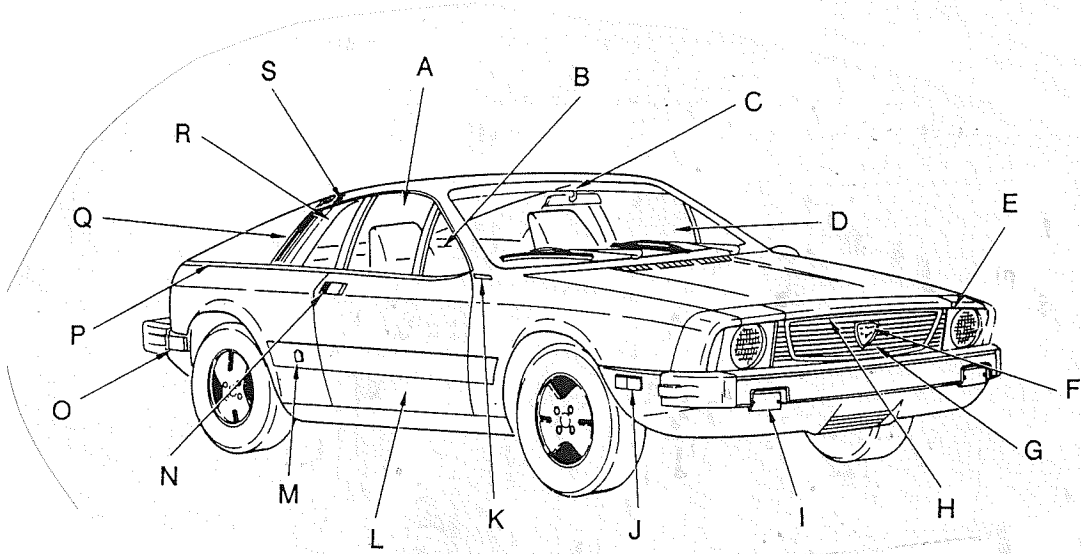

FIGURE #1

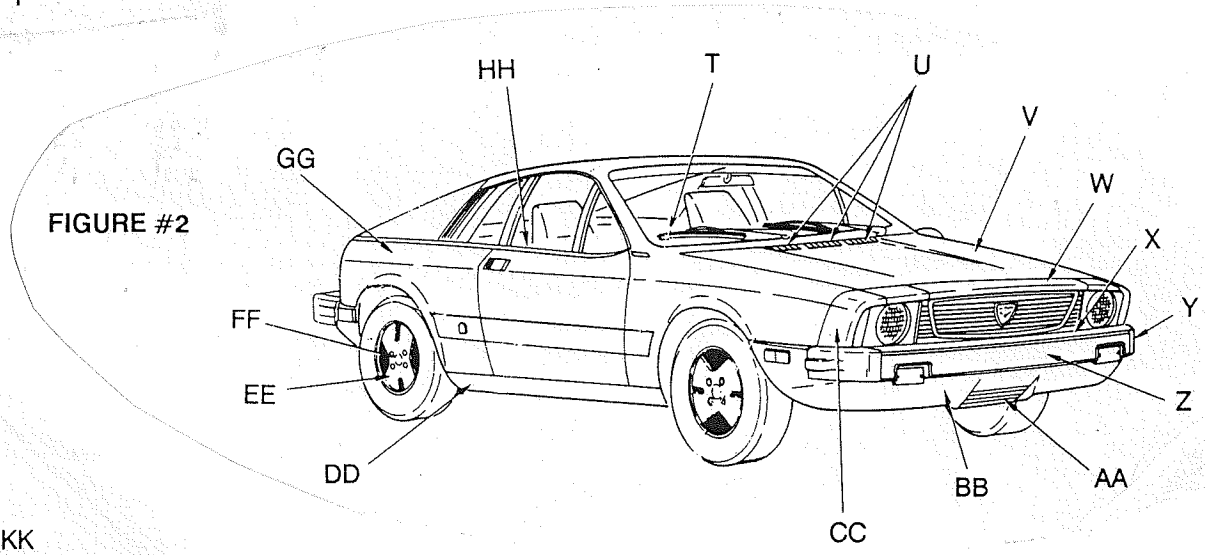

FIGURE #2

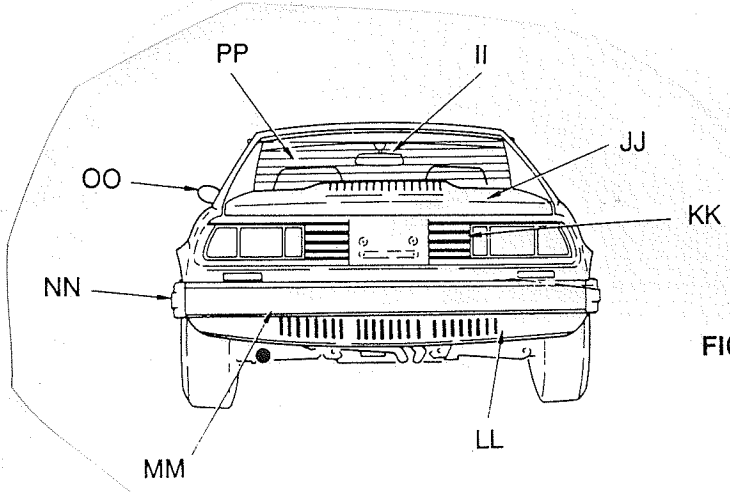

FIGURE #3

# LANCIA SCORPION and MONTECARLO BODY & TRIM

<u>ORDER #</u>	<u>FIGURE #1</u> <u>DESCRIPTION</u>
A-Left	Door Glass, Left
A-Right	Door Glass, Right
B-Left	Front Quarter Window, Left
B-Right	Front Quarter Window, Right
C	Windshield Tint (no lettering)
D	Windshield
E-Left	Headlamp Door, Left
E-Right	Headlamp Door, Right
F	Grille Badge
G	Front Grille
H	Front Grille Molding
I	Lens, Parking Lamp/Turn Signal
J	Front Side Marker Light, Yellow
K	Pininfarina Nameplate
L-Left	Door Shell, Left
L-Right	Door Shell, Right
M	"f" Crest
N-Left	Outer Door Handle, Left
N-Right	Outer Door Handle, Right
O	Rear Side Marker Light, Red
P-Left	Rear Quarter Panel Molding, Left
P-Right	Rear Quarter Panel Molding, Right
Q-Left	Extractor Grille, Left
Q-Right	Extractor Grille, Right
R-Left	Rear Quarter Window, Left
R-Right	Rear Quarter Window, Right
S-Left	Cap Piece for Extractor Grille, Left
S-Right	Cap Piece for Extractor Grille, Right

<u>ORDER #</u>	<u>FIGURE #2</u> <u>DESCRIPTION</u>
T	Factory Original Wiper Blade
U	Front Trunk Lid Grille
V	Front Trunk Lid
W	Upper Trim Panel (above front grille)
X	Fill Panel (between bumper & body)
Y-Left	Front Bumper Corner, Left
Y-Right	Front Bumper Corner, Right
Z	Front Bumper Impact Strip
AA	Lower Front Grille
BB	Front Lower Valence Panel
CC-Left	Front Quarter Panel Extension, Left

CC-Right	Front Quarter Panel Extension, Right
DD-Left	Rocker Panel, Left
DD-Right	Rocker Panel, Right
EE	Factory Original Alloy Wheel
FF	"L" Center Cap for Wheel
GG-Left	Rear Quarter Panel, Left
GG-Right	Rear Quarter Panel, Right
HH-Left	Upper Door Molding, Left
HH-Right	Upper Door Molding, Right

<u>ORDER #</u>	<u>FIGURE #3</u> <u>DESCRIPTION</u>
II	Inner Rear View Mirror
JJ	Engine Compartment Lid
KK	Rear Grille (without taillamps)
LL	Rear Lower Valence Panel
MM	Rear Bumper Impact Strip
NN-Left	Rear Bumper Corner, Left
NN-Right	Rear Bumper Corner, Right
OO	Vitaloni Side View Mirror
PP	Rear Window with Defroster

<u>ORDER #</u>	<u>NOT SHOWN</u> <u>DESCRIPTION</u>
QQ	Gas Gap, non-locking
RR	Plastic Screw for Rear Lenses (specify red, yellow or clear)
SS	Factory Original Black Lug Bolt
TT	Caribou Import's Scorpion Soft-Top
UU pair	Soft-Top Straps, left & right sold as a pair only)
V V	Handle to Open Trunk & Engine Lids
WW	Interior Lock Knob (on upper corner of door panel), brown only
XX	Original Window Winder Handle
YY	Foot Pad for Clutch or Brake Pedal
ZZ	Factory Original Tool Kit
AAA	Felt Channel for Door Glass (set of 3, enough for one door)
BBB	Red reflector in end of armrest
CAR014	Door Weatherstrip

The parts listed above are some of the more popular in our inventory, but we have available many other

parts for your Scorpion. Please inquire for any other interior or exterior items not listed here. We stock: lights, lenses, trim, weatherstrips, emblems, handles, locks and hundreds of other parts for your Scorpion.

## SCORPION SEAT REUPHOLSTERY KIT

Here it is! A Custom-Fit Reupholstery Kit for the Scorpion. Often an excellent condition Scorpion is flawed only by the condition of its seats. In answer to the many requests from Scorpion owners to cure this problem, Caribou Imports comes to the rescue! Our Reupolstery Kit is made to completely replace your worn seat upholstery (including the headrests) with a perfect fit, duplicating the original look and style exactly! Available in premium vat-dyed leather, heavy quality grained vinyl or grained vinyl with cloth center inserts, our Custom-Fit Reupholstery Kit will make your seats better than new! Normal production colors are dark red, black or saddle (tan), although other colors are available... please inquire. The Reupholstery Kit is custom made to your request, so please allow up to 5 weeks for delivery.

## CUSTOM FIT CARPETING KIT FOR SCORPION

The finishing touch on your restoration! Our Custom Carpeting Kit follows the exact dimensions of the Scorpion's floor for a perfect fit. This quality carpet is backed with padding to muffle noise and prolong the life of the carpet. It's then finished with color coordinated heel scuff pad, thread and binding. The Scorpion Carpet Kit does the entire interior except for the carpeting on the door panel, which is a part of the panel itself. Available in either luxurious pile or long-wearing loop in 12 colors: "Scorpion" red, tan, dark brown, biscuit (light tan), grey, black, dark green, gold, blue, silver blue, dark blue or maroon.

Our Custom Fit Carpet Kit is made to your request, so please allow 3-5 weeks for delivery and please note the kit is not returnable. Please specify color and your choice of durable loop or luxurious pile.

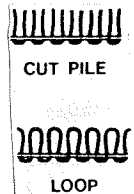



# CARIBOU



## CARIBOU IMPORTS MONTECARLO CONVERSIONS

*Update the looks of your classic Lancia Scorpion to those of the European MonteCarlo model with our Front and Rear Bumper Conversions!*



(left)  
Lancia Scorpion with:  
MonteCarlo Front End Conversion  
M/C Front Turn Signal/Parking Lights  
MonteCarlo Headlamps  
MonteCarlo Upper Trim Panel

(below)  
Lancia Scorpion with  
MonteCarlo Rear End Conversion



## MONTECARLO CONVERSIONS & SCORPION REPLACEMENT BODY PARTS

### CARIBOU IMPORTS MONTECARLO BUMPER CONVERSIONS

Now you can update the looks of your classic Lancia Scorpion to those of the European MonteCarlo model with our bolt-on Front and Rear Bumper Conversions! Each piece is constructed of hand-laid, multi-layer fiberglass and is stronger and less brittle than the original MonteCarlo plastic panels. They will not, however, withstand 5 mph impacts... as the MonteCarlo was not designed to. Each piece mounts directly in place of the Scorpion's front or rear bumper/lower valence panel assembly and comes with all necessary hardware and instructions. Painted matte black, they will handsomely add to your Scorpion's looks as is, or you may paint them to your taste. Your Scorpion's weight will be reduced by nearly 100 pounds, resulting in increased performance and handling. The Front Conversion works with either the stock "flip-up" headlights or may be combined with our MonteCarlo Headlights. The Rear Conversion is compatible with the stock exhaust, our Ansa Performance Exhaust or any other system that fits with the stock lower panel. You may use your stock Scorpion front turn signal/parking lamps or we can supply our MonteCarlo turn signal/parking lamp assembly that fits the opening for these lamps perfectly. The Conversions do not come pre-drilled for side marker lights unless you request it (at no additional charge). The MonteCarlo does not have side marker lights and we have found that most people do not use them when making the conversion. If necessary, the holes are easily drilled and the lights installed at a later date. The Front and Rear Conversions are each produced individually to your specifications, so please allow up to five weeks for delivery.

*"Your Scorpion's weight will be reduced by nearly 100 pounds, resulting in increased performance and handling."*

### MONTECARLO EUROPEAN TURN SIGNAL/PARKING LIGHTS

The MonteCarlo front turn signal/parking lamp assembly is different from the Scorpion's. Narrower and longer, it is more stylish and blends in with the front end styling of the car more harmoniously than the stock Scorpion assemblies do. Though you may use your stock Scorpion front turn signal/parking lamps in our MonteCarlo front bumper conversion, they definitely look too "chunky" and we recommend the European style assemblies that fit the openings perfectly. These front turn signal/parking lamp assemblies cannot be used with the stock USA bumpers, only with our conversion.

### MONTECARLO EUROPEAN HEADLIGHTS

The original factory headlights are available to put the finishing touch on your MonteCarlo conversion or to improve the looks of your Scorpion with stock bumpers. Imported from Italy, these lamps are beautiful additions to your Scorpion. They are supplied complete with mounting brackets and easy-to-replace quartz halogen bulbs. Please be advised that these lamps do not conform to NHSTA Regulations for use in the USA and are not legal except for off-road use in certain states. These are special order items and delivery is subject to the factory's availability. You will be advised upon receipt of your order.

### SCORPION & MONTECARLO UPPER TRIM PANEL

So many of the Scorpions we see have severely damaged or missing upper trim panels (between headlamp doors above the front grille), is your car one of them? The factory discontinued this piece years ago so replacement was impossible...until now! We are manufacturing reproduction fiberglass upper trim panels with molded-in metal mounting points. All in all, a sturdier, higher quality, finer finish part than the original and hundreds of dollars less than the original part too! The days of cracked panels

flying off on the highway are over! In addition, the MonteCarlo one piece, full width upper trim panel is produced in fiberglass with molded-in metal mounting points by our fiberglass shop. This piece is mandatory for proper installation of MonteCarlo headlights and advisable for any other conversion of Scorpion headlights. Both the Scorpion and MonteCarlo upper trim panels come in matte black, but will accept any other topcoats.

### SCORPION HEADLIGHT DOORS

Scorpion owners rejoice! Years after the factory discontinued the plastic headlight doors, Caribou Imports comes to the rescue. Now you can replace your broken or missing doors with our fiberglass reproductions. These doors are hand laid, thicker, stronger and of finer quality than the originals. Painted matte black, they bolt on as the originals do.

### SCORPION FRONT FENDER EXTENSION PANELS

If you view the Scorpion from the side, the forward section of the front fender is actually a plastic extension panel about the size of your hand and slightly curved. The factory discontinued this piece years ago, so once again Caribou Imports comes to the rescue! Our front fender extension panel is produced in hand-laid multi-layer fiberglass with molded-in metal mounting studs. It fits perfectly, is painted matte black and bolts on as the original did.

#### NOTES:

Please add shipping charges as described on our order form, except for MonteCarlo Front and Rear Conversions which are shipped via truck freight collect. The shipping charges on these Conversions will be collected by the delivering carrier at your door.

Price and availability on MonteCarlo Headlamps is subject to change without notice due to international currency exchange rates and the factory's delivery schedules.



LOOKING GOOD... With the Stylish Additions to your Scorpion from Caribou Imports



(Air Dam shown installed on our MonteCarlo Bumper Conversion, also fits on the stock front valence panel)

### THE SCORPION AIR DAM

In response to the unending requests from our customers, we are very pleased to offer The Scorpion Air Dam. A stylish and functional addition to your Scorpion, our two-piece Air Dam fits onto the stock USA lower valence panel or our MonteCarlo conversion panel (pictured above). Those of you who have driven a Scorpion at high speeds are always commenting on that scary feeling of losing control or "lightness" in the steering. This is due to the Scorpion's body being flat on bottom and curved on top. Have you looked at an airplane wing lately? Same shape in cross-section! This shape generates lift at speed and yes, your Scorpion would fly if you could get it going fast enough. Besides looking great, our air dam reduces the amount of air under the car by "spilling" it around to the sides thereby cutting down on lift. The difference is very noticeable! The lower center vent grille, which provides a cold air flow to the engine

*"your Scorpion would fly if you could get it going fast enough"*

compartment, is left unobstructed for maximum cooling. Produced with the typical Caribou Imports attention to quality, our sturdy Air Dam is hand laminated in triple-layer fiberglass. Easy to attach, the Air Dam comes painted matte black but will accept any primer or color topcoat you may choose to apply.

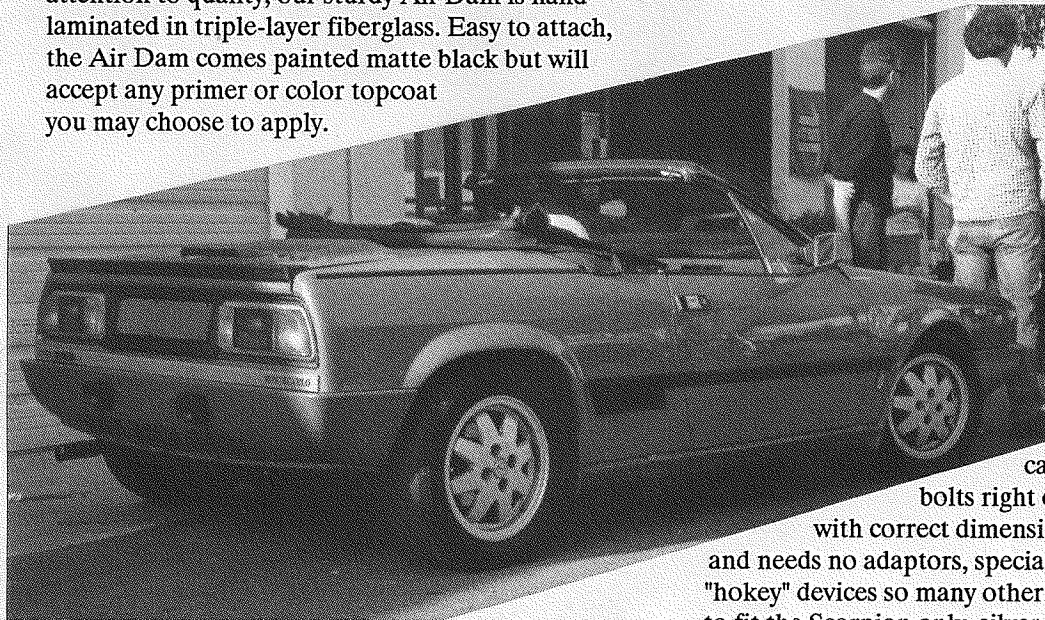

### NEW DOOR WEATHERSTRIPPING FOR THAT CONCOURS WINNING LOOK

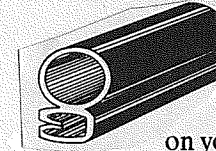

Is the wind whistling by your ears? Are your toes cold from an icy draft? Have you checked the weatherstripping on your door's opening lately? Most we see are torn and tattered? Nothing makes a great car look worse than opening the door and seeing worn-out old weatherstripping. The piece we are talking about, of course, is mounted on the body and the door closes onto it. But Lancia no longer supplies this weatherstripping and replacement was impossible until now. Our weatherstripping is made in the USA and is more durable and more resistant to ozone and other pollutants than the original Italian weatherstripping was. Plus: it is about 1/2 the price of what the factory was charging! Priced per piece, so two pieces are necessary to do both doors.

### PART NUMBER APPLICATION

CAR-014 Scorpion or MonteCarlo

### THE "PININ" WHEEL

The "PININ" wheel is designed by the same company responsible for the beautiful lines of your Scorpion. Available is an option on the very last MonteCarlo models in Europe, now this limited edition 14" x 6" wheel can grace your classic Scorpion. In our opinion this is surely the most beautiful wheel you can buy! The PININ bolts right on... as it is designed with correct dimensions for the Scorpion and needs no adaptors, special lug bolts or other "hokey" devices so many other wheels use. Available to fit the Scorpion only, silver finish with center caps.



## NEW MIRRORS ARE THE EASIEST WAY TO FRESHEN UP YOUR LANCIA'S LOOKS!

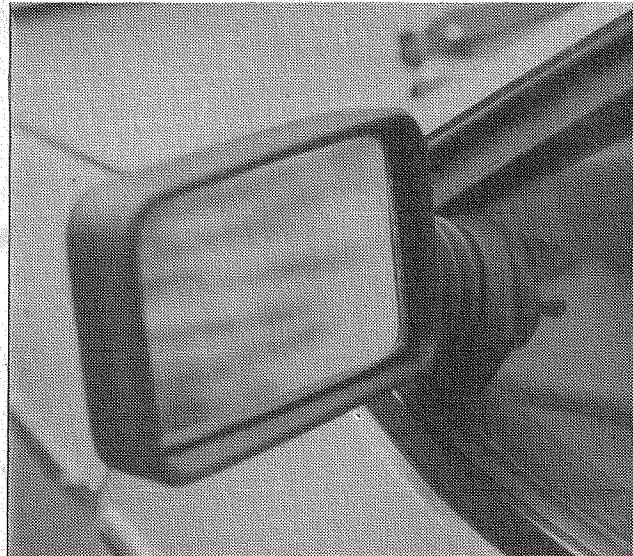

### UPDATE THE LOOKS OF YOUR SCORPION WITH OUR EXCLUSIVE "THROUGH THE WINDOW" MIRROR KITS

The latest in European styling can be yours with the exclusive Caribou Imports Mirror Update Kits! Now all Scorpion owners can have the same bold style as the Zagato and other European models! Our complete kit contains a Lancia OEM mechanical remote control mirror, plexiglass front quarter window with mirror installation hole, all necessary hardware and instructions. This is a true bolt-on kit requiring no cutting, drilling or other modifications. The pictures show a Scorpion driver side conversion, the passenger side mirror matches. Please remember that upon removal of your old door mounted mirror it's mounting holes will remain. If your Scorpion is due for some bodywork or paint, this will be an ideal time for our Mirror Conversions. Replacement mirrors are available seperately.

### VITALONI MIRRORS ITALIAN MADE AND THE FINEST QUALITY AVAILABLE



#### The Classic Californian

Lancia chose this mirror as the factory original for the Scorpion and MonteCarlo as did Ferrari for the original 308's. This is the only mirror to use for an accurate restoration. Please specify left or right side when ordering.

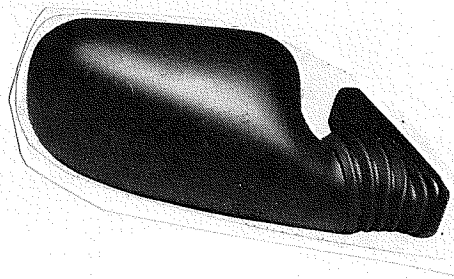

#### The Baby Turbo

Ferrari chose this mirror for the 512 Berlinetta Boxer. Looking to update the lines of your Scorpion or increase your field of vision to the rear? Then try a pair of these! Looks great on Coupes and Zagatos too. The Baby Turbo is reversible to fit the left or right side, so just order one or two as you wish.



#### The Baby Tornado

The mirror of choice for the HPE or Sedan. Slightly larger in size than either the Californian or Baby Turbo, it nicely compliments the larger size of the HPE and Sedan models. This is the classic "flag" style mirror for a wide field of vision. Please specify left or right side when ordering.

## BETA COUPE and ZAGATO BODY & TRIM

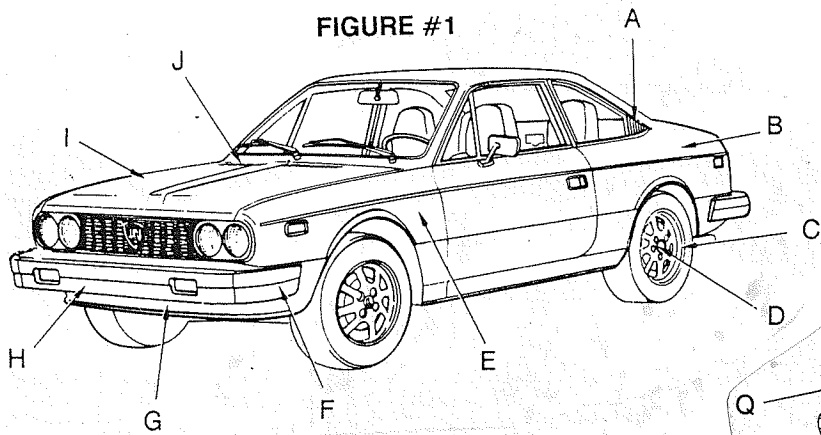

FIGURE #1

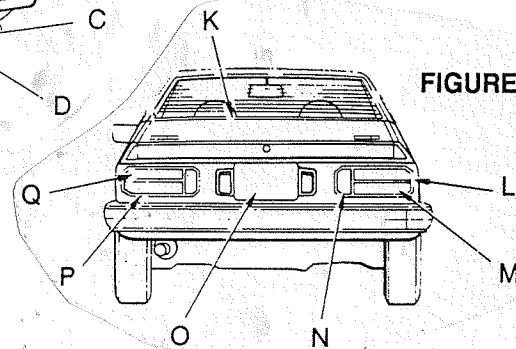

FIGURE #2

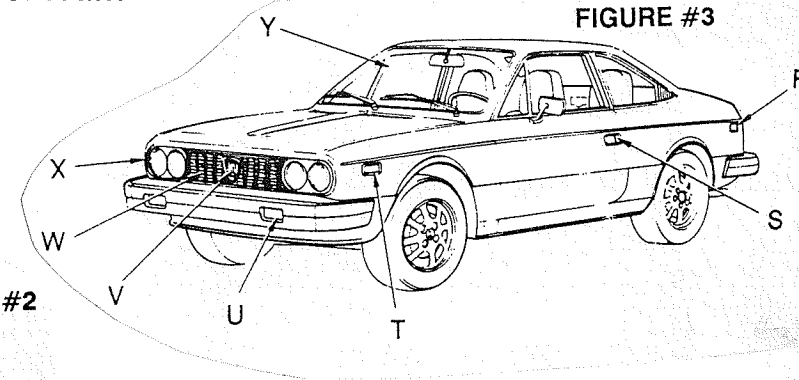

FIGURE #3

<u>ORDER #</u>	<u>DESCRIPTION</u>
A-Left	Extractor Grille, Left (Coupe)
A-Right	Extractor Grille, Right (Coupe)
B-Left	Rear Quarter Panel, Left (Coupe)
B-Right	Rear Quarter Panel, Right (Coupe)
C	Factory Original Alloy Wheel
D	"L" Center Cap for Wheel
E-Left	Front Quarter Panel, Left
E-Right	Front Quarter Panel, Right
F-Left	Front Bumper Corner, Left (79-82)
F-Right	Front Bumper Corner, Right (79-82)
G	Lower Front Panel
H	Front Bumper (1979-1982)
I-Early	Hood, 1975-1978
I-Late	Hood, 1979-1982
J-Left	Hood Grille, Left (1975-1978)
J-Right	Hood Grille, Right (1975-1978)
J-Late	Hood Grille (1979-1982)

<u>ORDER #</u>	<u>DESCRIPTION</u>
K-Cpe	Trunk Lid, Coupe
K-Zag	Trunk Lid, Zagato
L-Left	Taillamp Chrome Bezel Coupe, Left

L-Right	Taillamp Chrome Bezel Coupe, Right
M-Left	Taillamp & Brake Lens Coupe, Left
M-Right	Taillamp & Brake Lens Coupe, Right
N-Left	Reverse Light Lens Coupe, Left
N-Right	Reverse Light Lens Coupe, Right
O	License Plate Frame & Light Assembly
P-Left-Cpe	Taillamp Assembly Coupe, Left
P-Right-Cpe	Taillamp Assembly Coupe, Right
P-Left-Zag	Taillamp Assembly Zagato, Left
P-Right-Zag	Taillamp Assembly Zagato, Right
Q-Left	Turn Signal Lens Coupe Yellow, Left
Q-Right	Turn Signal Lens Coupe Yellow, Rt.

<u>ORDER #</u>	<u>DESCRIPTION</u>
R	Rear Side Marker Light, Red
S-Left	Exterior Door Handle, Left
S-Right	Exterior Door Handle, Right
T	Front Side Marker Light, Yellow
U	Lens, Parking Lamp/Turn Signal
V	Grille Badge (1975-1981)
W-Early	Grille with Badge (1975-1978)
W-Late	Grille with Badge (1979-1981)
W-Zag	Grille with Badge (1982 Zagato)

FIGURE #3

X-Left	Headlamp Bezel, Left (1975-1981)
X-Right	Headlamp Bezel, Right (1975-1981)
X-Left-82	Headlamp Bezel, Left (1982 Zagato)
X-Right-82	Headlamp Bezel, Rt (1982 Zagato)
Y	Windshield, Coupe or Zagato

<b>NOT SHOWN</b>	
<u>ORDER #</u>	<u>DESCRIPTION</u>
Z	Factory Original Wiper Blade, 79-82
AA	Interior Door Handle (Black Only)
BB	Window Winder Handle (1975-1978)
CC	Interior Lock Knob (on upper corner of door panel), brown only
CAR015	Door Weatherstrip, Zagato
CAR016	Door Weatherstrip, Coupe
CAR020	Trunk Weatherstrip, Coupe or Zagato
CA179	Zagato Soft-Top

Please inquire for any cosmetic interior or exterior parts for Coupe, HPE, Sedan or Zagato models that are not listed here. The listed parts are the more popular from our inventory, but we can supply virtually any item for your Lancia. We stock: lights, lenses, grilles, trim strips, weatherstrips, emblems, handles, locks and all other parts of your Lancia.

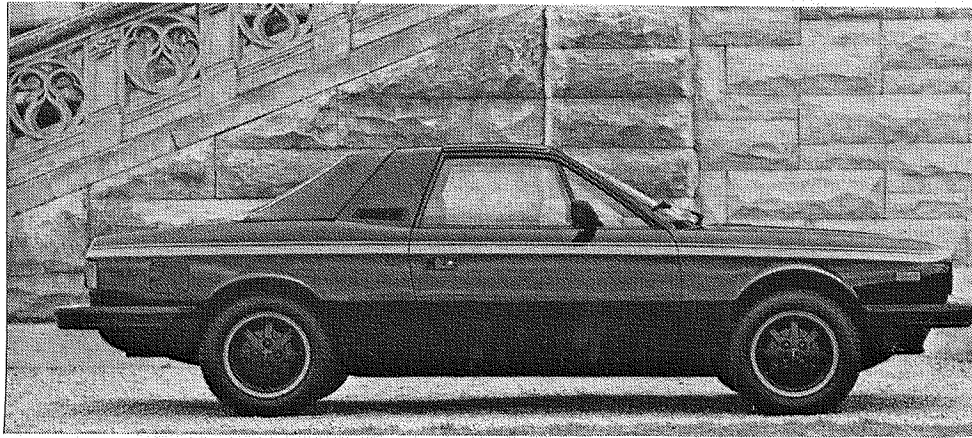

**THE ZAGATO SOFT-TOP**

As time goes by, we are receiving more and more requests from proud Zagato owners regarding parts for this very desirable Lancia. One of the most popular items for Zagatos is our CA-179 Zagato Soft-Top. Introduced by Caribou Imports nearly 10 years ago, there are literally hundreds and hundreds of Zagatos sporting our quality convertible top!

This is a virtual duplicate of the factory top, with the same style black crush-grain vinyl outside and a black cloth lining inside but, Caribou has made some improvements. We use only the finest material, a very durable and excellent looking 38 oz. crush-grain vinyl. All seams are stitched with dacron thread for superior strength and then sealed for the maximum protection against water leaks. The plastic rear window is slightly larger than the original top thereby offering an increased field of vision to the rear and it's made from a D.O.T approved material.

The CA-179 is one of our most popular parts and is always available from our stock for immediate shipment to you. Why wait weeks ordering from somewhere else and wind up paying ten, twenty or hundreds of dollars more?

CA-179 Zagato Soft-Top

**ZAGATO CONVERTIBLE TOP BOOT**

We have been asked many times about a "boot" to cover the soft top when it's down. A boot was supplied with every Zagato, but by now it's usually de-

stroyed or lost. Often it was separated from the car when first sold at the dealer and never even given to the original owner! We have the original Zagato top boots as supplied by Lancia in Italy and they are the finishing touch for any Zagato owner! The looks of your Zagato with the top down will now be enhanced greatly as this black boot really gives a "finished" look to the car. Plus, you'll be protecting your soft top from the sun and other potential damage.

CA-180 Zagato Convertible Top Boot

**NEW DOOR WEATHERSTRIPPING FOR THAT CONOURS WINNING LOOK**

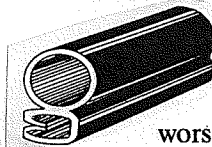

Is the weatherstripping on the car body where your doors open torn and tattered? Nothing makes a great car look worse than opening the door and seeing worn-out, old weatherstripping. But, Lancia no longer supplies this particular weatherstripping so replacement was impossible; that is until Caribou made some! Our weatherstripping is made in the USA and is more durable and resistant to ozone and other pollutants than the original Italian weatherstripping was. Plus: it is about 1/2 the price of what the factory part cost! Weatherstripping is priced per piece, so two pieces are necessary to do both doors.

PART NUMBER	APPLICATION
CAR-015	Zagato Door Weatherstrip
CAR-016	Coupe or HPE Door Weatherstrip

**TRUNK LID NAMEPLATE BADGES FOR LANCIA BETA COUPE AND ZAGATO**

The badge from the factory is a poor quality silkscreen that will fade when exposed to sunlight or simply be "wiped off" the first time someone goes over your car with a power buffer. If your car is like all the rest, these badges are difficult to read and just look terrible! Once again, Caribou to the rescue!



(badges shown smaller than actual size)

We have made excellent quality, self-adhesive 3M Brand mylar "badges" that are simply applied on top of the existing metal badge already on your car. Just clean off the surface of your old badge, peel the backing paper from the new "badge" and lay it in place... simple! Instantly, your Lancia looks better than new; plus our "badges" are far more durable than the original silkscreening was. A black background with silver lettering in the same style as the original makes our badges look absolutely "factory original" once in place on your car. Three different styles are available:

- LANCIA (for the left side of all cars)
- ZAGATO (right side of Zagato models)
- 2000 (right side of Beta Coupes and other models)

TRUNK LID NAMEPLATE BADGE	
PART NUMBER	APPLICATION
BADGE-L	Lancia Badge
BADGE-Z	Zagato Badge
BADGE-2000	2000 Badge

Prevent fading, cracking and chalking of both the interior and exterior with any of our Custom-Fit or Easy-Fit Covers.

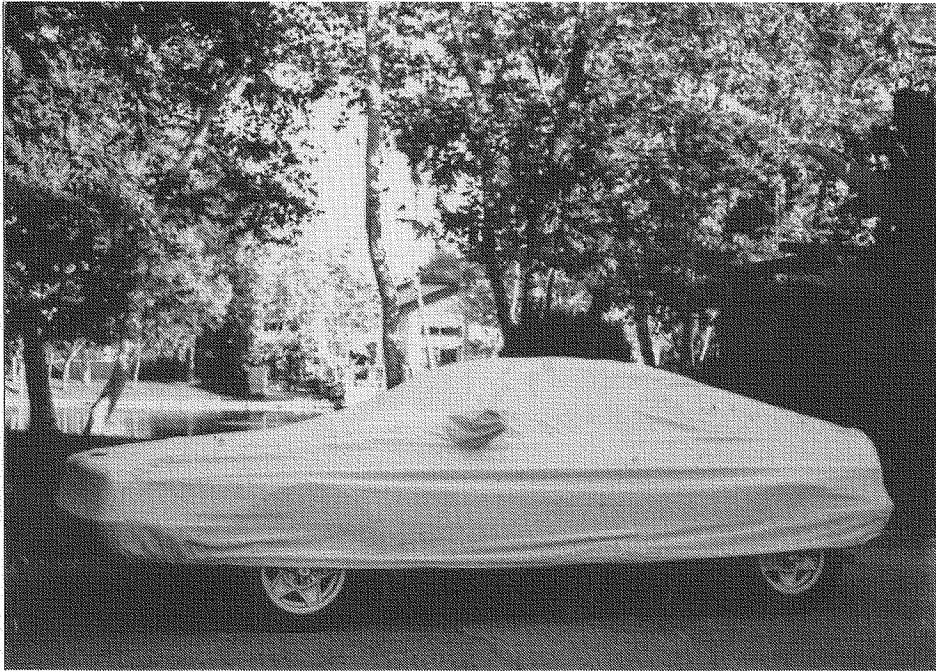

#### CUSTOM-FIT CAR COVERS FOR YOUR LANCIA

**FINALLY...** A Custom Fit Car Cover for the Scorpion and MonteCarlo (or Scorpion with our exclusive MonteCarlo Conversion). Yes, our patterns are so accurate that we have a different cover for each model! Both are made from our famous light-blue poly-cotton to reduce heat and protect your Lancia's fine finish. We have thoughtfully provided mirror "pockets" on both sides which will fit stock mirrors, any of our Vitaloni mirror replacements, or our exclusive "through the window" mirror conversions. Give your collector-quality Lancia the protection it deserves with either of the exclusive Caribou Imports Custom-Fit Covers.

#### CUSTOM-FIT CAR COVERS

CA-146 Custom-Fit Car Cover for MonteCarlo (and MonteCarlo converted Scorpion)  
CA-165 Custom-Fit Car Cover for Scorpion

#### EASY-FIT CAR COVERS FOR YOUR LANCIA

Made from the same poly-cotton material as our Custom-Fit Covers, these Easy-Fit Covers provide an economical alternative while providing more complete coverage for Lancia models. Easy-Fit Covers do not come with mirror pockets, and are not custom cut for each model, but they pass our stringent standards for fit and snugness so well you'd swear they were! Now all Lancia owners can protect their cars from the harmful effects of sun, moisture and dew, birds and atmospheric pollutants.

#### EASY-FIT CAR COVERS

CA-1 Easy-Fit Car Cover for Lancia Stratos, MonteCarlo (and MonteCarlo converted Scorpion)  
CA-2 Easy-Fit Car Cover for Lancia Coupe, Zagato & Scorpion  
CA-3 Easy-Fit Car Cover for Lancia Beta HPE & Sedan

#### CAR COVER LOCK

All our Custom-Fit and Easy-Fit Car Covers, come with grommets already installed for use with our Cover Lock. This cable and padlock system secures the cover around your car making it impossible to remove without the padlock's key. Ideal for those "risky" parking areas or for long-term storage where your Lancia will not be in frequent sight. Our Cover Lock is an excellent all-around security measure not only for your cover, but the entire car!

CA-LOK Car Cover Lock

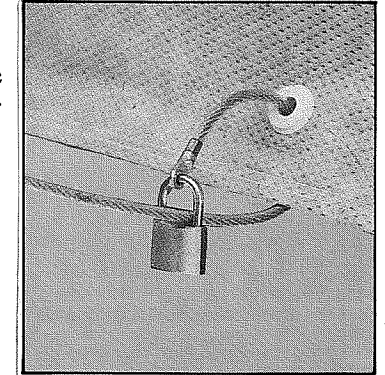

#### NOW AVAILABLE! EVOLUTION 3 FABRIC AS AN OPTION FOR ALL CARIBOU IMPORTS CAR COVERS!

The new Evolution 3 fabric by Kimberly-Clark brings space-age technology to protect your Lancia! All our Custom-Fit and Easy-Fit car covers are now available in this amazing material. Evolution 3 is a thick, padded and textured material that is virtually opaque which means practically no sunlight or ultraviolet rays will reach your car. The thickness of Evolution 3 helps absorb bumps, dings, minor impacts, falling branches, hail and more thereby protecting your car as no other material can. Rainstorms can be trouble, but Evolution 3 is an all-weather material! It's water resistant, plus it's breathable so when the rains have gone, Evolution 3 allows the moisture to evaporate, and it won't rot or mildew. Evolution 3 costs a bit more, but isn't your Lancia worth it?

#### EVOLUTION 3 MATERIAL OPTION

Any Custom-Fit or Easy-Fit Car Cover made with Evolution 3 material, add the "EV" to the model number (example: CA-165 would be CA-165EV).



## OUR MOST POPULAR ACCESSORY !!!

Those of you who had purchased any of our beautiful Plush Carpet Mats in the past or bought a car that had a set already in it have always commented on the precision fit, beauty and durability of them even years after they were put in the car. These mats are just one of the fine products from our shelves; we are proud to offer products like these that meet our high standards.

Our Deluxe Plush Carpet Mats are a luxurious deep pile floor carpeting for your Lancia, Maserati or Fiat. Each set is *custom fitted* to your exact year and model and made from 100% nylon for lasting beauty. Our mats are waterproof and backed on the reverse side with Non-Slip Foam. This is the finest product you can put in your car! For a slight additional charge we will silkscreen the Lancia crest logo, Maserati trident crest or Fiat slanted block letter logo in contrasting color onto any of our mats. On non-logo mats a color-coordinated rubber heel mat is attached to the driver's side. Please specify year, model, color desired and if the logo is desired.

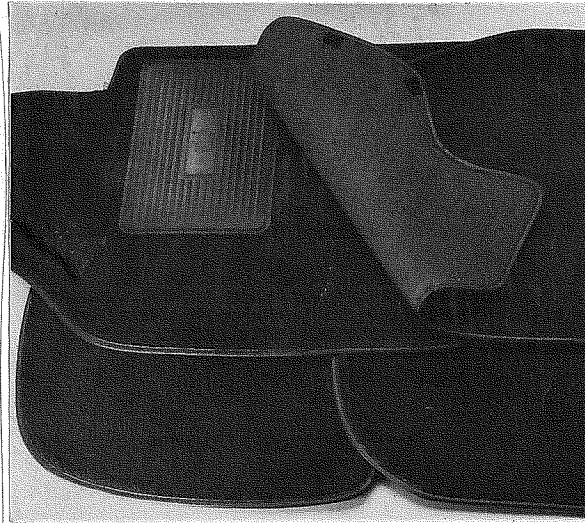

### DELUXE PLUSH MATS

Available in:

- Black
- Red
- Tan
- Dark Blue
- Silver Grey
- Burgundy (a near perfect match for red Scorpion interiors)
- Dark Brown (recommended for tan and brown interiors)
- Charcoal (a near perfect match to the grey plastic in Scorpion interiors)

#### AVAILABLE FOR CAR MODEL

- Lancia Scorpion, set of 2
- Lancia Scorpion Front Trunk Mat
- Lancia Coupe, HPE, Sedan or Zagato, set of 4, (front & rear)
- Lancia Zagato Trunk Mat
- Maserati Biturbo, all 2-door, 4-door or Spyder, set of 4 (front & rear)
- Maserati Biturbo, all 2-door Trunk Mat
- Maserati Biturbo, all 4-door Trunk Mat
- Fiat 124/2000/Pininfarina Spider, set of 2 (front only)
- Fiat 124/2000/Pininfarina Spider, Trunk Mat
- Fiat X1/9, set of 2 (front only)
- Fiat 850 Spider, set of 2 (front only)

#### PRICE CODE WITH LOGO

- C
- A
- A
- C
- C
- C

#### PRICE CODE WITHOUT LOGO

- E
- D
- B
- D
- B
- D
- D
- E
- D
- E
- E

#### LOGOS AVAILABLE





### LANCIA BASEBALL CAP

A smart looking corduroy baseball style cap in the famous "Lancia" dark blue color with 3-color Lancia crest. A very high-quality cap to compliment your good taste in cars. One size fits all.



### LANCIA KEY CHAIN

Attached to the black leather grain fob is a beautiful 3-color enameled metal Lancia crest. This is a very nice way to show your loyalty to your Lancia!



### LANCIA DESK PEN SET

A high-quality 3-color enameled metal Lancia crest highlights the dramatic onyx base with attached ball point pen & holder. The Lancia Desk Pen Set is a beautiful addition to your home or office.

### MOMO STEERING WHEELS

The standard of excellence for years! Original equipment for Ferrari street cars and virtually every Formula 1 race team, all Momo wheels are constructed for durability, strength and of course beauty. All steering wheels include the correct hub adapter for your car with a Lancia crest horn button. Momo steering wheels are made with the finest materials and hand craftsmanship.

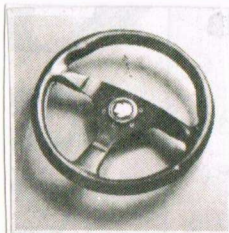

#### MONTECARLO

Named after the European version of the Scorpion, this wheel looks and feels great! You'll love the sculptured fit of the Montecarlo wheel with it's 350 mm (13 3/4 inch) diameter, semi-dish shape. Available in black leather with red, white or black stitching and brown leather with brown stitching

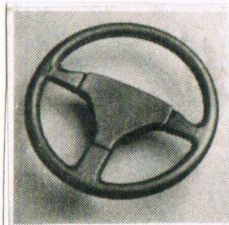

#### COBRA

The ultimate wheel for your Lancia! Special contouring of the grip area will make you think the Cobra was designed just for you! The stylish center pad adds a luxurious touch! 360 mm (14 1/8 inch) diameter, semi-dish. Available in black leather with red or white stitching.

### MOMO GEARSHIFT KNOB

The Momo Gearshift Knob is absolutely the most beautiful and functional knob we've ever seen. Everyone will notice the beauty and luxury of your new designer gearshift knob, but what you will love is the comfort and sporty grip from the contoured design. Makes gear shifting a pleasure! Fits all years, all models, except automatic transmission. Available in black leather with black or white stitching, brown leather with brown stitching or in beautiful polished wood.

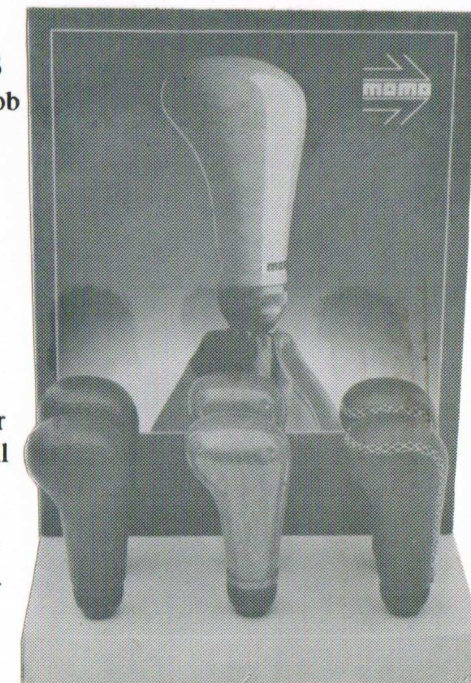

Printed in USA  
CII, div LPD 0791

© All copyrights reserved 1991  
Caribou Imports, Inc