

ENGINE - 10

PARTS CATALOG,
SERVICE MANUAL &
SERVICE TIME
SCHEDULE CODE

		PAGE
10	Specifications	10-1
	Torque Specifications	10-10
100.00	Engine Assembly	10-13
	Removal and Installation	10-17
	Disassembly	10-23
	Assembly	10-28
101.01	Crankcase and Cylinder Head	10-33
101.02	Oil Sump and Crankcase Covers	10-49
101.03	Crankshaft and Flywheel	10-51
101.05	Connecting Rods and Pistons	10-57
101.06	Camshaft Drive	10-63
101.07	Valve Mechanism	10-67
101.15	Auxiliary Drives	10-77
102.01	Fuel Tank and Lines	10-79
102.02	Fuel Pump and Lines	10-83
102.04	Carburetor and Air Cleaner	10-87
102.22	Accelerator Linkage	10-101
102.26	Fuel Injection System	10-103
102.58	Exhaust and Emission Control System	10-117
102.80	Turbocharger	10-133
103.01	Lubrication	10-149
104.01	Cooling System	10-159
10A	Service Tools	10-169

CYLINDER BLOCK CON-RODS

DESCRIPTION	IN.	MM							
Cylinder bore diameter	3.3070 to 3.3090	84.000 to 84.050							
Cylinder bores are graded into classes with 0.0004 in (0.01 mm) progression.									
Auxiliary shaft bushing seats, diameters:									
– belt end	2.0126 to 2.0138	51.120 to 51.150							
– flywheel end	1.6547 to 1.6559	42.030 to 42.060							
Crankshaft bearing saddle bore diameter	2.2329 to 2.2334	56.717 to 56.730							
Length of rear main bearing bore between thrust ring seats	0.9095 to 0.9134	23.100 to 23.200							
Big-end bore diameter	2.1219 to 2.1225	53.897 to 53.913							
Small-end bore diameter	0.9424 to 0.9438	23.939 to 23.972							
Small-end bushing O.D.	0.9455 to 0.9465	24.016 to 24.041							
Small-end bushing I.D., fitted and finish reamed	<table border="0"> <tr> <td rowspan="2" style="font-size: 2em; vertical-align: middle;">}</td> <td>Class 1</td> <td>0.8662 to 0.8664</td> <td>22.004 to 22.007</td> </tr> <tr> <td>Class 2</td> <td>0.8664 to 0.8665</td> <td>22.007 to 22.010</td> </tr> </table>	}	Class 1	0.8662 to 0.8664	22.004 to 22.007	Class 2	0.8664 to 0.8665	22.007 to 22.010	
}	Class 1		0.8662 to 0.8664	22.004 to 22.007					
	Class 2	0.8664 to 0.8665	22.007 to 22.010						
Thickness of standard big-end bearings (2000 eng.)	0.0603 to 0.0605	1.5338 to 1.537							
Thickness of standard big-end bearings (1800 eng.)	<table border="0"> <tr> <td>Class A (*)</td> <td>.0599 to .0600</td> <td>1.521 to 1.525</td> </tr> <tr> <td>Class B (**)</td> <td>.0600 to .0602</td> <td>1.525 to 1.529</td> </tr> </table>	Class A (*)	.0599 to .0600	1.521 to 1.525	Class B (**)	.0600 to .0602	1.525 to 1.529		
Class A (*)	.0599 to .0600	1.521 to 1.525							
Class B (**)	.0600 to .0602	1.525 to 1.529							
Range of undersize big-end bearings for service	0.010-0.020-0.030-0.040	0.254-0.508-0.762-1.016							
Small-end bushing fit: interference	0.0017 to 0.0040	0.044 to 0.102							
Piston pin-small-end bushing fit:									
– clearance	0.0004 to 0.0006	0.010 to 0.016							
Big-end bearings:									
– fit clearance (2000 eng.)	0.0008 to 0.0025	0.021 to 0.065							
Big-end bearings:									
– fit clearance (1800 eng.)	<table border="0"> <tr> <td>Class A</td> <td>.0018 to .0031</td> <td>.045 to .079</td> </tr> <tr> <td>Class B</td> <td>.0019 to .0032</td> <td>.047 to .081</td> </tr> </table>	Class A	.0018 to .0031	.045 to .079	Class B	.0019 to .0032	.047 to .081		
Class A	.0018 to .0031	.045 to .079							
Class B	.0019 to .0032	.047 to .081							
Maximum misalignment between C/Ls of connecting rod small-end and big-end: – measured at 4.92 in (125 mm) from the shank	0.0031	0.08							

(*) Color-coded with red paint.
 (**) Color-coded with blue paint.

PISTON-PINS-RINGS

DESCRIPTION		IN.	MM
Diameter of standard pistons, measured at right angles to C/L of piston ring at 1.181 in (30 mm) from piston skirt edge	{ Class A	3.3051 to 3.3055	83.950 to 83.960
	{ Class C	3.3059 to 3.3063	83.970 to 83.980
	{ Class E	3.3066 to 3.3070	83.990 to 84.000
Oversize piston range		0.0079-0.0157-0.0236	0.2-0.4-0.6
Piston boss bore diam.	{ Class 1	0.8660 to 0.8661	21.996 to 21.999
	{ Class 2	0.8661 to 0.8662	21.999 to 22.002
Piston ring groove width	{ Top groove	0.0604 to 0.0612	1.535 to 1.555
	{ Center groove	0.0798 to 0.0806	2.030 to 2.050
	{ Bottom groove	0.1561 to 0.1569	3.967 to 3.987
Standard piston pin diam	{ Class 1	0.8658 to 0.8659	21.991 to 21.994
	{ Class 2	0.8659 to 0.8660	21.994 to 21.997
Oversize piston pin		0.0079	0.2
Piston ring thickness:			
– first compression ring		0.0582 to 0.0587	1.478 to 1.490
– second oil ring		0.0779 to 0.0787	1.980 to 2.000
– third oil ring with oilways and expander		0.1544 to 0.1549	3.925 to 3.937
(*) Piston fit in bore (measured at right angles to pin):			
– fit clearance		0.0016 to 0.0024	0.040 to 0.060
Piston pin in boss: fit clearance		0.0001 to 0.0003	0.002 to 0.008
Piston ring side clearance:			
– first compression ring: fit clearance		0.0018 to 0.0030	0.045 to 0.077
– second oil ring: fit clearance		0.0011 to 0.0027	0.030 to 0.070
– third oil ring: fit clearance		0.0011 to 0.0024	0.030 to 0.062
Piston ring end gap in bore:			
– first compression ring: fit clearance		0.0118 to 0.0177	0.30 to 0.45
– second oil ring: fit clearance		0.0118 to 0.0177	0.30 to 0.35
– third oil ring: fit clearance		0.0098 to 0.0157	0.25 to 0.40
Oversize piston ring range:			
– compression and oil rings		0.0079-0.0157-0.0236	0.2-0.4-0.6

(*) Measured at 1.876 in. (47.65 mm) from piston head.

CRANKSHAFT AND MAIN BEARINGS

DESCRIPTION	IN.	MM
Main bearing journal standard diam.	2.0860 to 2.0868	52.985 to 53.005
Main bearing saddle bore	2.2329 to 2.2334	56.717 to 56.730
Standard main bearing insert thickness (2000 eng.)	{ Class 1 0.722 to 0.724	1.834 to 1.840
	{ Class 2 0.724 to 0.726	1.839 to 1.845
Standard main bearing insert thickness (1800 eng.)0718 to .0721	1.825 to 1.831
Main bearing inserts for service	0.01-0.02-0.03-0.04	0.254-0.508-0.762-1.016
Crankpin standard diameter	{ Class A 1.9997 to 2.0001	50.792 to 50.802
	{ Class B 1.9993 to 1.9997	50.782 to 50.792
Main bearing-to-journal fit: - fit clearance (2000 eng.)	0.0012 to 0.0030	0.032 to 0.077
Main bearing-to-journal fit: - fit clearance (1800 eng.)0020 to .0037	.050 to .095
Length of rear main bearing journal, shoulder-to-shoulder	1.1014 to 1.1034	27.975 to 28.025
Width of rear main bearing seat, between thrust ring seats	0.9095 to 0.9134	23.100 to 23.200
Rear main bearing seat thrust ring thickness	0.0909 to 0.0929	2.310 to 2.360
Oversize thrust ring thickness	0.0959 to 0.0979	2.437 to 2.487
Crankshaft end clearance, thrust rings installed: - fit clearance	0.0021 to 0.0120	0.055 to 0.305
Maximum misalignment of main bearing journals (total indicator reading) (2000 eng.)	0.0011	0.03
Maximum misalignment of main bearing journals (total indicator reading) (1800 eng.)0008	0.02
Maximum misalignment of crankpins to main bearing journals	0.013	0.35
Maximum out-of-round of crankpins and main bearing journals, after grinding	0.0002	0.005
Maximum taper of crankpins and main bearing journals, after grinding	0.0002	0.005
Squareness of flywheel resting face to crankshaft centerline: - max. out-of-true with dial indicator set laterally some 1.3 in (33 mm) apart from crankshaft rotation axis	0.0010	0.025

Flywheel:

— parallel relationship of driven plate
resting face to crankshaft flange

mounting face: max. out-of-true 0.0039 0.10

— squareness of above faces to rotation

axis: max. out-of-true 0.0039 0.10

101



Engine: Specifications

10

Page 10-5

CYLINDER HEAD

DESCRIPTION	IN.	MM	
Valve guide seat bore (2000 eng.)	0.5492 to 0.5502	13.950 to 13.977	
Valve guide seat bore (1800 eng.)5886 to .5896	14.950 to 14.977	
Valve guide O.D., standard (2000 eng.)	0.5527 to 0.5534	14.040 to 14.058	
Valve guide O.D., standard (1800 eng.)5905 to .5912	14.998 to 15.016	
Valve guide oversize on O.D., for service (2000 eng.)	0.0019–0.0039– 0.0098–0.0177	0.05–0.10– 0.25–0.45	
Valve guide oversize on O.D., for service (1800 eng.)0079	.2	
Fit between valve guide and bore in head: interference (2000 eng.)	0.0024 to 0.0042	0.063 to 0.108	
Fit between valve guide and bore in head: interference (1800 eng.)0008 to .0026	.021 to .066	
Inside diameter of valve guides, fitted in cylinder head	0.3158 to 0.3165	8.022 to 8.040	
Valve stem diameter	0.3139 to 0.3146	7.974 to 7.992	
Fit between valve stem and guide: – fit clearance	0.0012 to 0.0026	0.030 to 0.066	
Valve seat angle in cylinder head	45° ± 5'		
Valve face angle	45° 30' ± 5'		
Valve head diameter (2000 eng.)	intake exhaust	1.6377 to 1.6535 1.4114 to 1.4350	41.60 to 42.00 35.85 to 36.45
Valve head diameter (1800 eng.)	intake exhaust	1.6614 to 1.6772 1.4115 to 1.4350	42.20 to 42.60 35.85 to 36.45
Max. eccentricity of valve head in one complete turn guided by stem, with indicator set on center of contact face	0.0012	0.03	
Width of valve seat in cylinder head (contact face), abt	0.079	2	
Inside diameter of valve seats in cylinder head (2000 eng.)	intake exhaust	1.4566 to 1.4645 1.2755 to 1.2834	37.00 to 37.20 32.40 to 32.60
Inside diameter of valve seats in cylinder head (1800 eng.)	intake exhaust	1.4134 to 1.4213 1.2756 to 1.2835	35.90 to 36.10 32.40 to 32.60
Lift on valve C/L (without play)	0.3765	9.564	
Diameter of tappet bores in head	1.4567 to 1.4576	37.000 to 37.025	
Outside diameter of tappets	1.4557 to 1.4565	36.975 to 36.995	
Fit clearance between tappets and bores in head	0.0002 to 0.0020	0.005 to 0.050	
Thickness of tappet cap plates: basic dimension	0.1575 ± 0.0004	4 ± 0.01	
Tappet caps are supplied for service in the following thicknesses: .1280, .1299, .1339, .1378, .1417, .1457, .1496, .1535, .1575, .1614, .1654, .1693, .1732, .1772, .1811, .1850 in. (3.25, 3.30, 3.40, 3.50, 3.60, 3.70, 3.80, 3.90, 4.00, 4.10, 4.20, 4.30, 4.40, 4.50, 4.60, 4.70 mm)			

101

VALVE SPRINGS

DESCRIPTION	INNER SPRING	OUTER SPRING
Spring height under a load of 85.5 lbs. (38.9 kg)	—	1.417 in (36 mm)
Spring height under a load of 32.7 lbs. (14.9 kg)	1.220 in (31 mm)	—
Minimum permissible load referred to the above heights	32 lbs. (14.5 kg)	79.4 lbs. (36 kg)

VALVE MECHANISM

DESCRIPTION	IN.	MM
Diameter of camshaft journal bores in head:		
— front	1.1814 to 1.1824	30.009 to 30.034
— middle	1.8031 to 1.8042	45.800 to 45.825
— rear	1.8189 to 1.8198	46.200 to 46.225
Diameter of camshaft journals:		
— front	1.1788 to 1.1795	29.944 to 29.960
— middle	1.8013 to 1.8020	45.755 to 45.771
— rear	1.8171 to 1.8178	46.155 to 46.171
Camshaft journal to bore fit:		
— fit clearance	{ front 0.0019 to 0.0035	0.049 to 0.090
	{ middle 0.0011 to 0.0027	0.029 to 0.070
	{ rear 0.0011 to 0.0027	0.019 to 0.070

AUXILIARY DRIVE SHAFT

Diameter of bushing bores in crankcase:		
— front	2.0126 to 2.0138	51.120 to 51.150
— rear	1.6547 to 1.6559	42.030 to 42.060
Inside diameter of bushings finished in bores:		
— front	1.8930 to 1.8938	48.084 to 48.104
— rear	1.5354 to 1.5362	39.000 to 39.020
Diameter of shaft journals:		
— front	1.8903 to 1.8913	48.013 to 48.038
— rear	1.5326 to 1.5336	38.929 to 38.954
Fit between bushings and bores in crankcase: interference fit		
	0.00314 to 0.0035	0.08 to 0.151
Fit between bushings and shaft journals:		
— fit clearance	{ front 0.0018 to 0.0036	0.046 to 0.091
	{ rear 0.0018 to 0.0036	0.046 to 0.091

CARBURETORS

Year	Type, Weber	Venturi Diameter MM	Main Jet MM	Idle Jet MM	Emulsion Tube MM	Air Corrector Jet MM	Pump Jet MM	Needle Valve MM	Float Level MM	Position Primary Throttle on Full Choke MM
75-76	32ADFA 2/100 (49 State)	*23	1.25	0.50	F74	1.85 1.70	0.50	1.75	*** 6.5	1.05/1.15
	32ADFA 5/100 (Calif.)	**25	1.40	0.60	F74	1.80 1.70				
77	32ADFA 12/100 (49 State)	*23	1.25	0.50	F73	1.85 1.70	0.50	1.75	*** 6.5	1.05/1.15
	32ADFA 15/101 (Calif.)	**25	1.40	0.60	F7	1.75 1.70				
78	32ADFA 11/100 (49 State)	*23	1.25	0.50	F73	1.85 1.70	0.50	1.75	*** 6.5	1.05/1.10
	32ADFA 14/101 (Calif.)	**25	1.40	0.60	F7	1.75 1.70				
79	28/32ADHA 3/179 (49 State - S/T)	*22	1.20	0.55	F84	1.75	0.50	1.75	*** 6.5	1.00/1.10
	28/32ADHA 4/179 (49 State - A/T)	**24	1.15	0.60	F7	1.60				1.05/1.15
	28/32ADHA 7/179 (Calif - S/T)	*22	1.20	0.55	F84	1.70 1.70	0.50	1.75	*** 6.5	1.00/1.10
	28/32ADHA 8/179 (Calif - A/T)	**24	1.15	0.60	F7	1.65 1.70				1.05/1.15
80	28/32ADHA 7/180 (Std. Trans.)	*22 **24	1.20 1.15	0.55 0.60	F84 F7	1.70 1.70	0.50	1.75	*** 6.5	1.00/1.10
	28/32ADHA 8/180 (Auto. Trans.)	*22 **24	1.20 1.15	0.55 0.60	F84 F7	1.65 1.70				

*Primary Throat
 **Secondary Throat
 ***Tolerance ± 1 MM

80 and on	BOSCH L-JETRONIC FUEL INJECTION
-----------	---------------------------------

10

LUBRICATION

Oil pump	gear type
Oil pump drive	by auxiliary shaft
Oil pressure relief valve	built in oil pump
Clearance between gears upper end and pump cover mating face	0.0010 to 0.0051 in. (0.026 to 0.131 mm)
Clearance between gears and pump housing inside wall	0.0043 to 0.0071 in. (0.110 to 0.180 mm)
Fit between drive spindle guide bushing and bore in crankcase	interference at all times (0.0010 to 0.0027 in. [0.025 to 0.070 mm])
Clearance between drive spindle and bushing press fitted in crankcase	0.0012 to 0.0026 in. (0.032 to 0.067 mm)
Clearance between drive gear spindle and bore in pump body	0.0006 to 0.0021 in. (0.016 to 0.055 mm)
Clearance between pin and driven gear	0.0007 to 0.0022 in. (0.017 to 0.057 mm)
Lash between matched gears	0.006 in. (0.15 mm)
Lash between drive spindle gear and auxiliary shaft gear	0.0023 in. (0.06 mm)
Full-flow oil filter with by-pass valve	cartridge type
Low oil pressure indicator sending unit	electric tell-tale
Lubrication pressure at 212°F (100°C)	50 to 71 psi (3.5 to 5.0 Kg/sq. cm)

OIL PRESSURE RELIEF VALVE SPRING

Length of seated spring under a load of 13.67 ± 0.55 lbs. (6.2 ± .25 kg)	0.886 in. (22.5 mm)
Minimum permissible load referred to length of seated spring	12.78 lbs. (5.8 kg)

COOLING SYSTEM

Water circulation cooling system:	
– Water pump	centrifugal vane type
– Water pump drive	by belt
– Radiator cooling fan	four bladed fan driven by electric motor controlled by thermal switch
Radiator fan thermal switch:	
– cuts in at	194° to 201°F. (90° to 94°C)
– cuts out at	185° to 192°F. (85° to 89°C)

Engine: Specifications

10

Page 10-9

Thermostat:

- begins opening at 172° to 180° F (78° to 82° C)
- opening at 198° F (92° C),
equal to or more than 0.29 in. (7.5 mm)

Fit clearance between impeller vanes
and pump body

0.04 in. (1 mm)

Radiator cap valve opening pressure
Water temperature indicator

11.4 p.s.i. (0.8 Kg/sq. cm)
electrical gauge

10

TORQUE SPECIFICATIONS

DESCRIPTION	THREAD (METRIC)	MATERIAL	TORQUE		
			N·m	FT.LB.	Kgm
Bolt, center main bearing cap	M12 x 1.25	R100	113	83	11.5
Bolt, front main bearing cap	M10 x 1.25	R100	80	59	8.2
Bolt, self-locking, main bearing cap . .	M12 x 1.25	R100	113	83	11.5
Bolt, engine breather mounting	M8	R80 Znt	24	17	2.3
Bolt, cylinder head hold-down	M10 x 1.25	R100	83	61	8.5
Bolt, cylinder head extensions	M8	8.8 Znt/Deidr	22	14	2
Bolt, cylinder head extensions	M8	8.8 Znt/Deidr	22	14	2
Nut, intake manifold-to-cylinder head stud	M8	R50 Znt (Stud R80 Znt)	25	18	2.5
Bolt, intake manifold	M8	8.8 Cdt/Deidr	25	18	2.5
Nut, exhaust manifold-to-cylinder head stud	M8	R50 Znt (Stud R80 Znt)	25	18	2.5
Nut, connecting rod bolt	M10 x 1	R80 - BON (Bolt 12 R) 30 Cd 4Pb BON (Bolt 12 R)	75	54	7.5
Bolt, flywheel-to-crankshaft	M12 x 1.25	38 Cd-4Rct-BON or 40Ni-Cr-Mo- Trf-Rct 120-135 Kg/mm ²	145	105	14.5
Nut, belt tensioner	M10 x 1.25	R50 Znt (Stud R100)	44	33	4.5
Bolt, camshaft sprocket	M12 x 1.25	12.9	118	87	12
Bolt, oil pump body and scoop	M8	8.8	22	14	2
Bolt, oil filter	M10 x 1.25	8.8 Znt/Deidr	51	36	5
Nut, alternator, and water pump	M20 x 1.5	R50 Znt Waxed or Oiled (Shaft 40 Cr-Mo-4 BON)	245	181	25
Bolt, oil filter support	M10 x 1.25	8.8 Znt/Deidr	51	36	5
Bolt, water pump pulley	M8 x 1.25	8.8 Znt/Deidr	24	17	2.3
Nut, alternator to crankcase	M12 x 1.25	R80 Znt (Bolt 8.8 Znt/Deidr)	69	51	7
Self-locking nut, with nylon, alternator upper bracket	M10 x 1.25	R50 Znt (Bolt 8.8 Znt/Deidr)	43	32	4.4
Bolt, alternator upper bracket	M10 x 1.25	8.8 Znt/Ec	71	52	7.2
Union, diverter valve vacuum port . .	M10 x 1.5 taper	R50 TRF Znt	13	11	1.5
Nut, air pump bracket	M10 x 1.25	R50 Znt (Stud R80 Znt)	25	18	2.5

TORQUE SPECIFICATIONS

DESCRIPTION	THREAD (METRIC)	MATERIAL	TORQUE		
			N·m	FT.LB.	Kgm
Nut, air pump support stud	M10 x 1.25	R50 Znt (Bolt B80 Znt)	51	36	5
Nut, air pump support	M8	R50 Znt (Bolt R80 Znt)	28	20	2.8
Bolt, air pump bracket	M10 x 1.25	R80 Edt	52	38	5.3
Bolt, air pump pulley	20 UNC - 2A	R50 Znt	6	4	0.6
Plug, EGR pipe fitting	M16 x 1.5	R50 Znt	54	40	5.5
Switch, oil pressure	M14 x 1.5	Steel CDT or Znt	31	24	3.3
Switch, water temperature	M16 x 1.5 taper	Brass	49	36	5
Spark plugs	M14 x 1.25	—	37	27	3.8

**Components with new coating Znt/EC

Warning! — Znt/EC coating involves a variation in the tightening torque reference. Components coated with Znt/EC are olive green colored, and torque figures are as follows:

Bolt, air pump bracket	M10 x 1.25	8.8 Znt/EC	71	52	7.2
----------------------------------	------------	------------	----	----	-----

WITH TURBOCHARGING

DESCRIPTION	TORQUE FT. LB.
Turbocharger to exhaust manifold bolts	20
Exhaust manifold nuts	22
Outlet elbow to turbocharger bolts	22
Outlet elbow to exhaust pipe nuts	22
Turbocharger support bracket to cylinder block bolts	22
Outlet elbow support bracket to cylinder block nuts	30
Plenum support bracket to plenum bolt	12
Spark plugs	14
Lambda sensor	30
Exhaust manifold heat shield	22

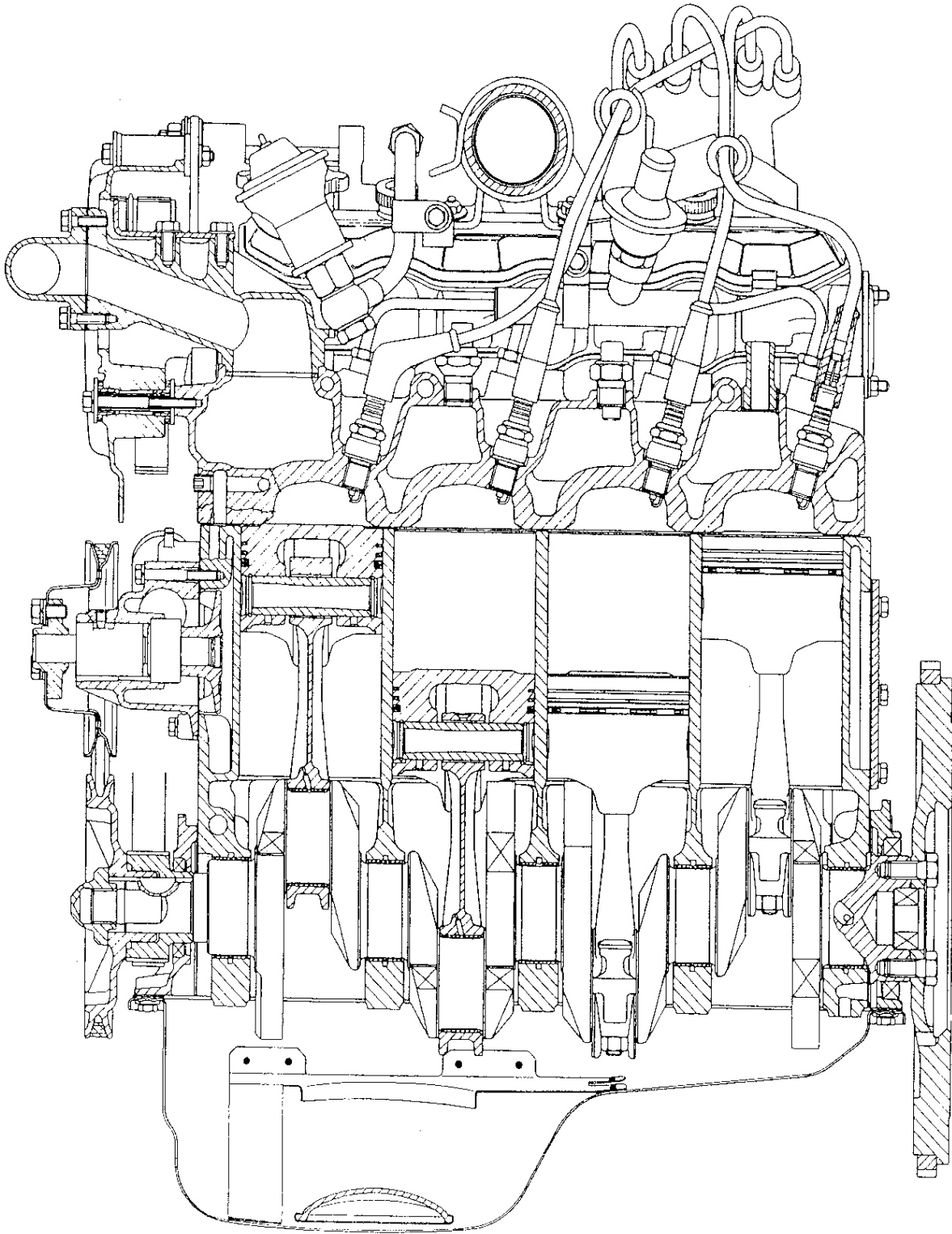

10

ENGINE CROSS SECTION

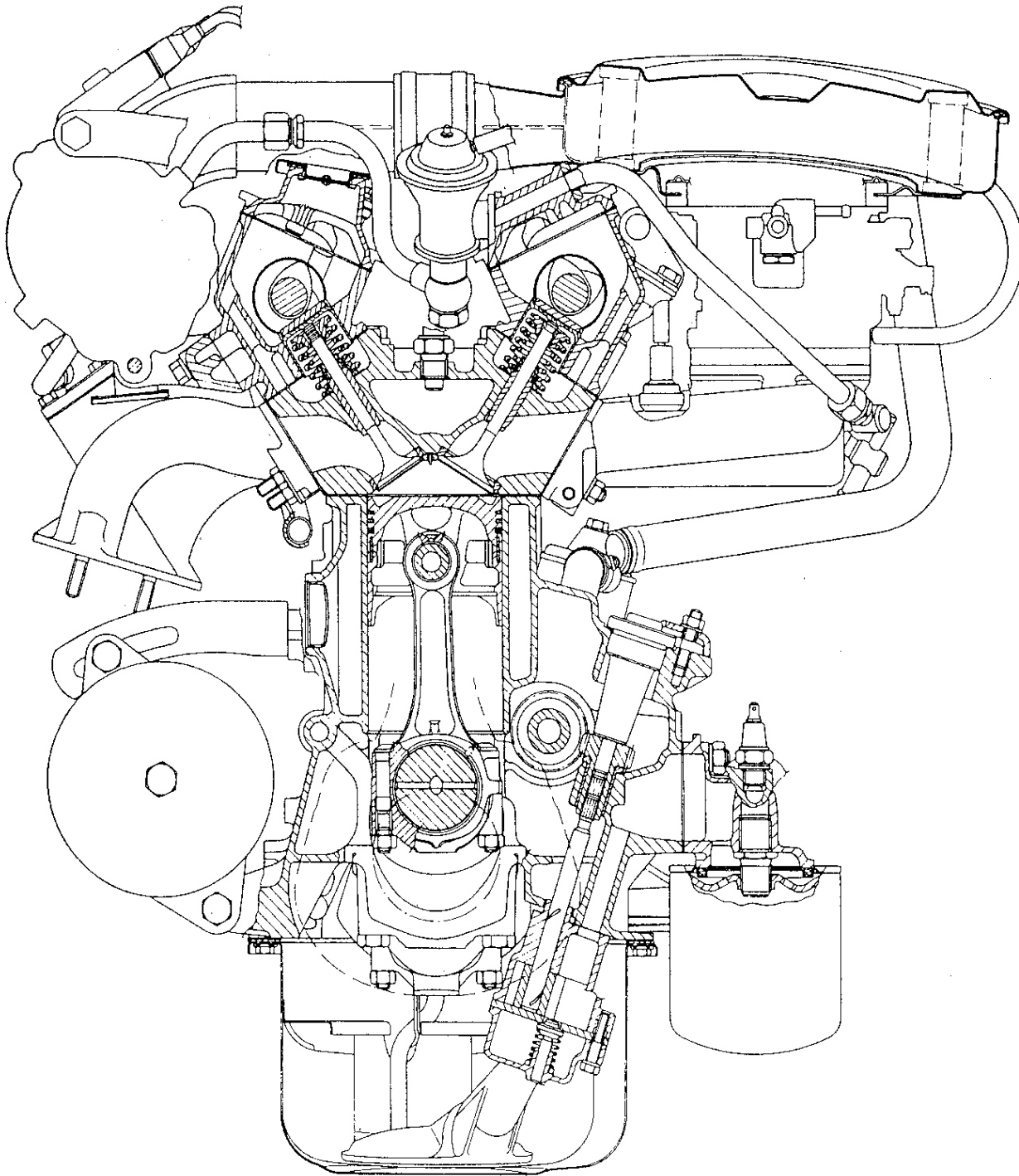

ENGINE CROSS SECTION

**FOLD OUT
PAGE GOES
HERE**

**REFER TO
FOLDOUT.PDF**

ENGINE

REMOVAL AND INSTALLATION

Disconnect battery ground cable located in trunk. Loosen fuel tank filler cap to release any fuel pressure.

Remove hood (refer to Body Section). Remove four screws to remove hood spring.

Drain radiator thru plug on lower left side of radiator. Drain engine coolant thru plug in lower right side of block.

The following procedures refer to carbureted engines:

Remove three nuts (1) holding air cleaner top cover (2).

Remove all air and vacuum lines to air cleaner.

Remove four nuts holding air cleaner to carburetor. Lift air cleaner up high enough to disconnect lines underneath. Remove air cleaner assembly (3) and all attached lines.

1. Nut 2. Air cleaner top cover 3. Air cleaner assembly

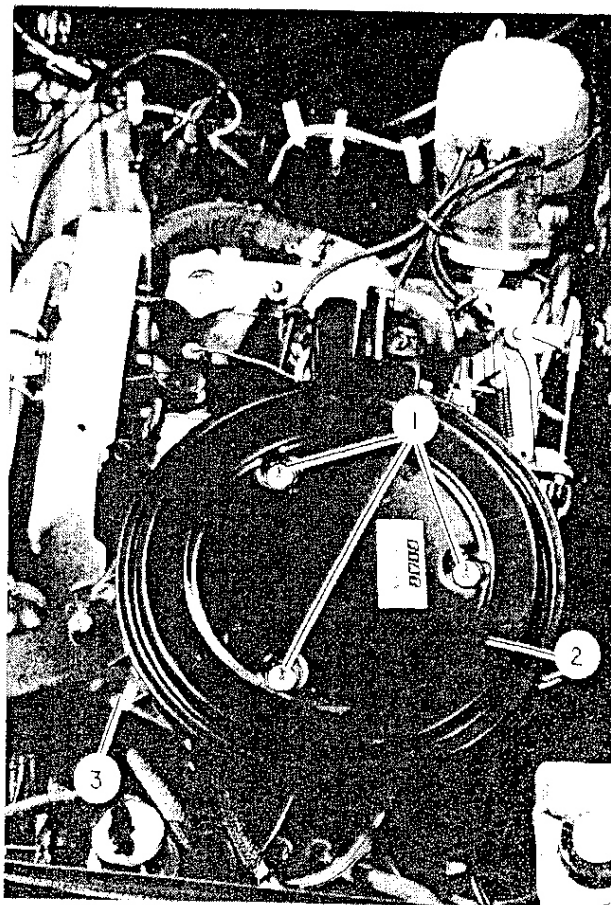

On left side of engine, mark to identify, then disconnect fuel inlet line (1), fuel return line (2), fuel vapor line (3), EGR line (4), power brake vacuum line (5), vapor canister vacuum line (6), gulp valve vacuum lines (7) and carburetor electrical connector to solenoid (8).

Disconnect throttle rod (9) at linkage (10) on top of engine. Remove two nuts attaching linkage to camshaft cover, and lay linkage to one side.

Mark to identify, then disconnect two water temperature switches electrical connectors from top of cylinder head.

Disconnect vacuum line from intake manifold to automatic transmission, if equipped with automatic transmission.

Disconnect electrical leads at alternator and starter. Disconnect oil pressure switch electrical connector at oil filter.

1. Fuel inlet line 2. Fuel return line 3. Fuel vapor line 4. EGR line
5. Power brake vacuum line 6. Vapor canister vacuum line 7. Gulp valve vacuum lines 8. Idle stop solenoid 9. Throttle rod
10. Throttle linkage 11. Water temperature switch

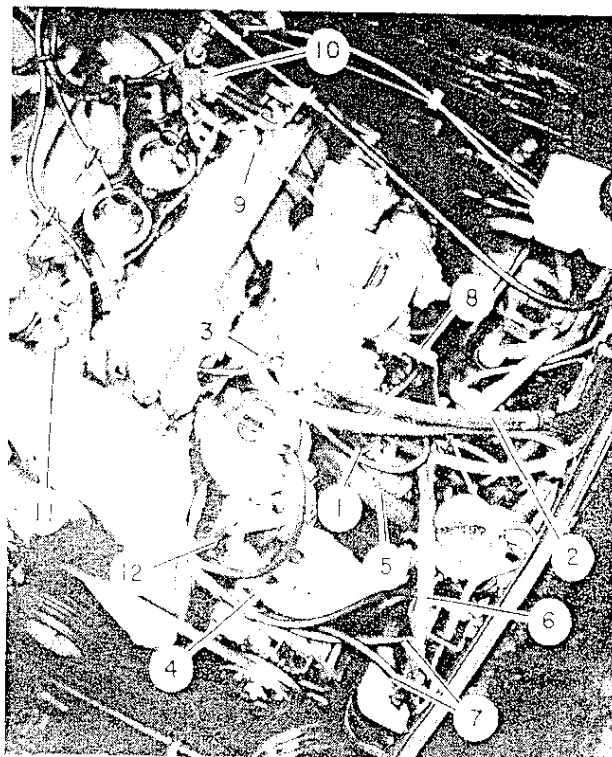

On right side of engine, loosen clamps (1) and disconnect two heater core hoses at firewall.

On vehicles with automatic transmission, disconnect dipstick tube from right cam housing.

Disconnect distributor white lead wire (2) connector at electronic control module mounted on right fender shield.

Disconnect coil high tension lead (3) at distributor.

Disconnect module ground wire from rear of right cam housing (4).

1. Clamp 2. Distributor lead wire 3. High tension lead 4. Right cam housing

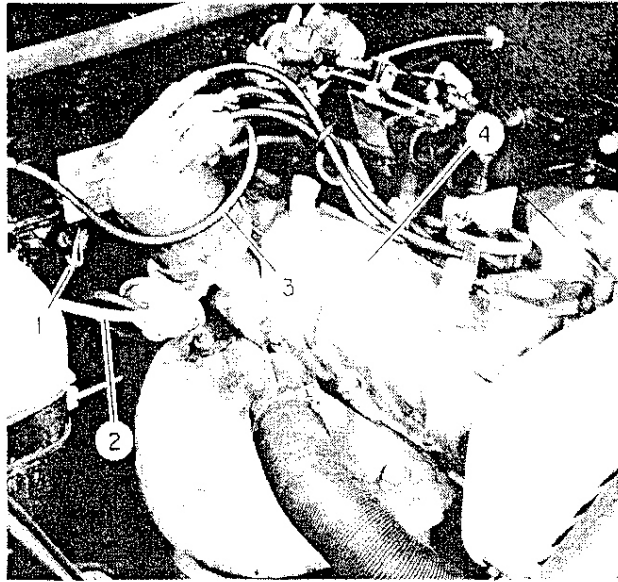

The following procedures refer to fuel injected engines:

Remove air intake line (1) by loosening three clamps (2).

1. Air intake line 2. Clamp

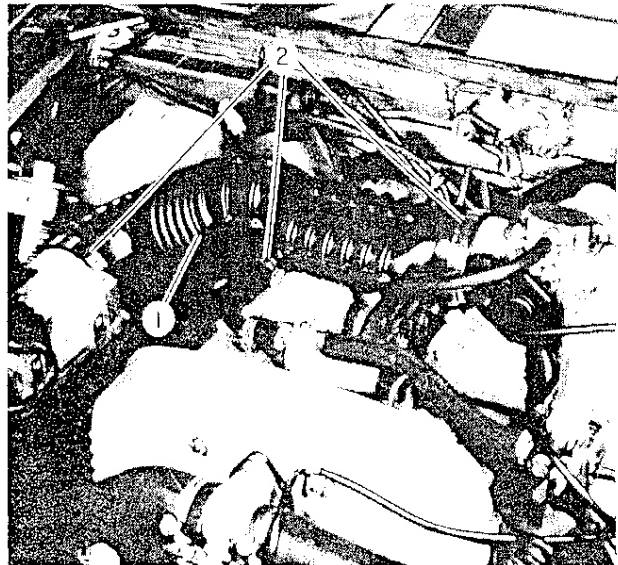

Disconnect electrical connector (1) from air flow sensor (2). Release four catches (3) holding air filter cover to housing (4), and remove filter element (5).

Remove housing by removing three nuts and washers.

1. Electrical connector 2. Air flow sensor 3. Catch 4. Air filter housing 5. Filter element

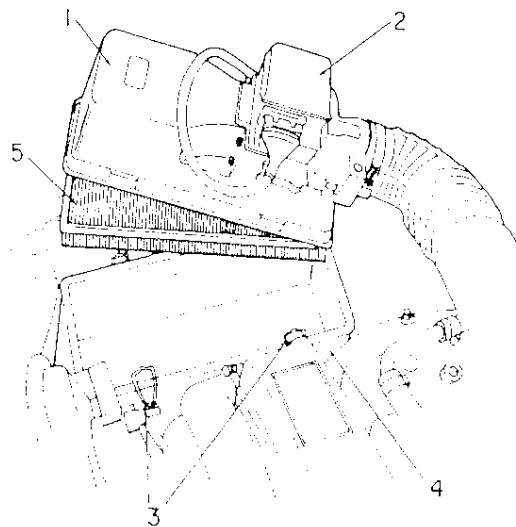

10

Loosen clamps to remove power brake vacuum line (1) and vapor canister vacuum line (2) from intake manifold fittings. Disconnect vacuum line to automatic transmission, if so equipped.

Remove bolts and clamps (3) securing wire harness (4) to intake manifold. Disconnect all electrical connectors coming out of harness (pull connectors straight out).

1. Power brake vacuum line 2. Vapor canister vacuum line 3. Clamp
4. Electrical harness

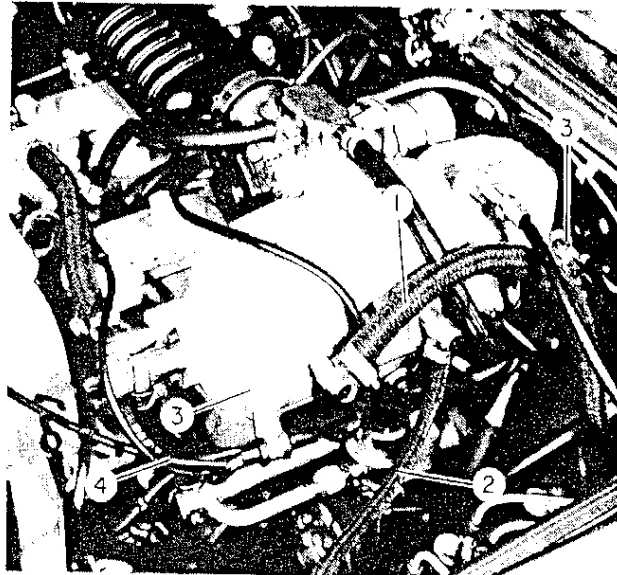

Rotate throttle lever (1) and remove throttle cable (2).

CAUTION: Note for reassembly that both adjustment nuts (3) are on the left side of mount (4). To assemble otherwise will result in erratic throttle operation.

1. Throttle lever 2. Throttle cable 3. Adjustment nuts 4. Throttle cable mount

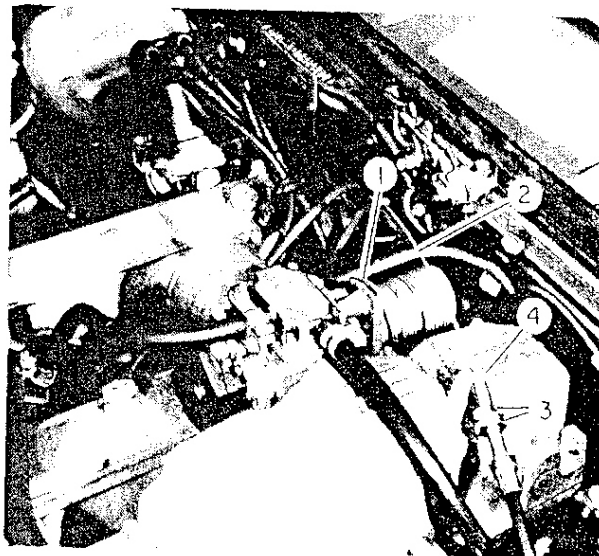

Before disconnecting fuel lines to engine, fuel pressure must first be released.

Remove fuel tank filler cap.

Remove vacuum hose (1) from fuel pressure regulator (2).

Using a hand vacuum pump (3) apply about 25 inches of vacuum to pressure regulator as shown. Fuel system pressure will then be released into fuel tank.

1. Vacuum hose 2. Fuel pressure regulator 3. Hand vacuum pump

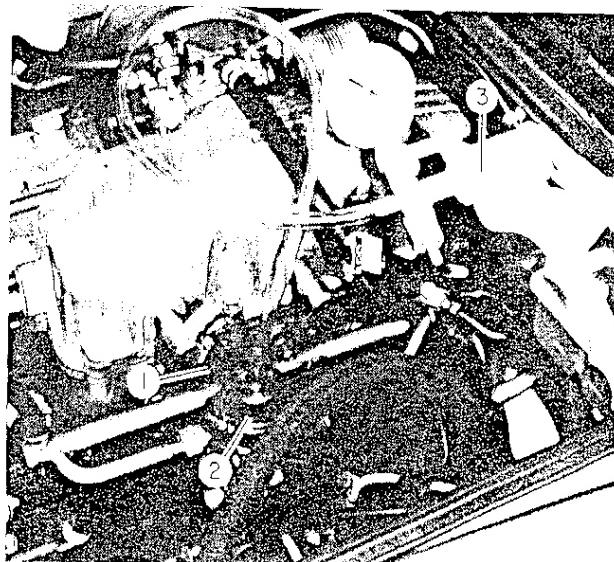

WARNING: Take all necessary precautions to prevent a fire when fuel lines are opened.

CAUTION: The fuel injection system is highly susceptible to contamination. Make sure area is clean whenever lines are opened, and that dirt does not enter system.

Disconnect fuel return hose (1) from regulator (2). Disconnect fuel supply flex line fitting (3) from metal line (4) near left fender shield.

- 1. Fuel return hose
- 2. Fuel pressure regulator
- 3. Fuel supply line
- 4. Metal fuel supply line from pump

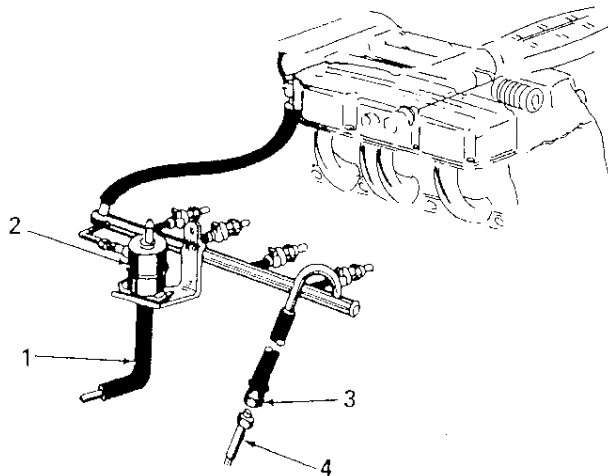

Disconnect crankcase breather hose (1). Disconnect starter (2) and alternator (3) electrical leads.

Disconnect oil pressure electrical connector at oil filter.

Mark to identify, then disconnect two water temperature switches electrical connectors from top of cylinder head.

- 1. Crankcase breather hose
- 2. Starter
- 3. Alternator
- 4. Fuel supply line
- 5. Fuel pressure regulator

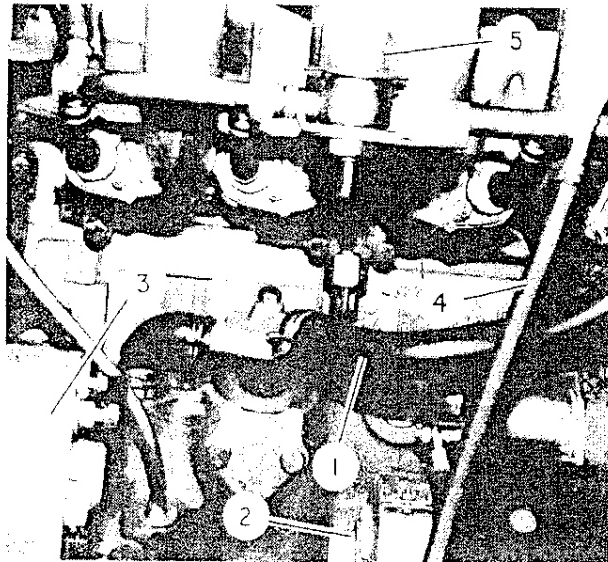

On right side of engine, loosen clamps and disconnect two heater core hoses at firewall.

On vehicles with automatic transmission, disconnect dipstick tube from cam housing.

Remove plastic nut (1) and clamp holding wire harness.

Disconnect Lambda sensor connector (2).

Disconnect distributor white lead wire (3) connector at electronic control module.

Disconnect coil high tension lead at distributor.

Disconnect engine ground wire from rear of right cam housing.

- 1. Plastic nut
- 2. Lambda sensor connector
- 3. Distributor lead wire

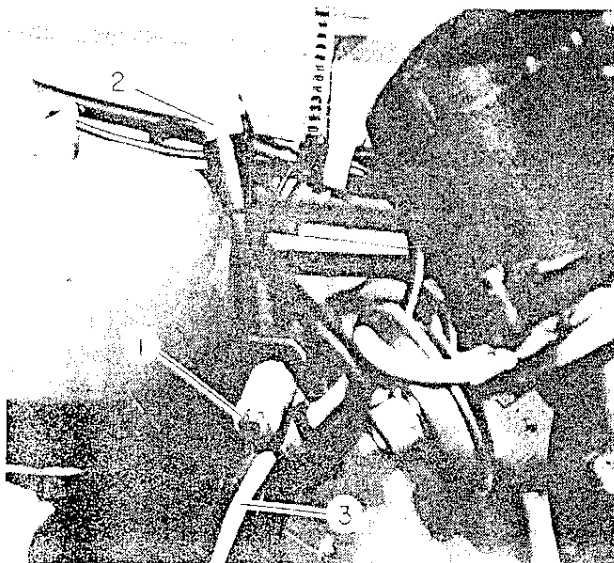

If engine is equipped with a turbocharger, disconnect the following in addition to most items covered under fuel injected engines.

On left side of engine disconnect vacuum lines (1) to turbo pressure switches (2).

1. Vacuum line 2. Turbo pressure switch

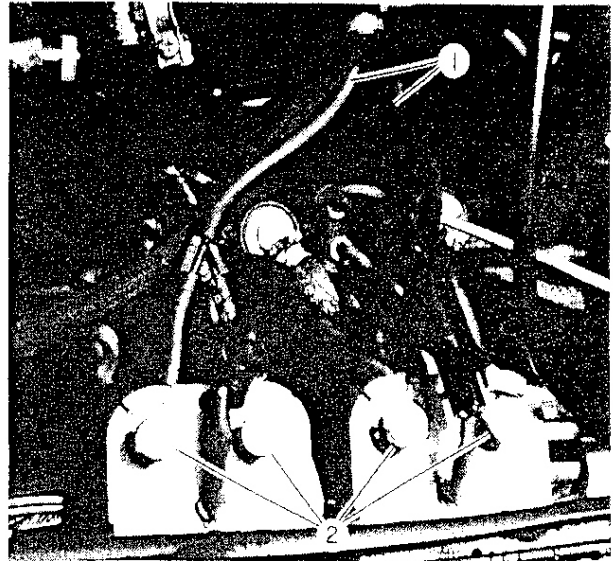

The following procedures refer to all engines:

Remove radiator (refer to Cooling in this section).

Remove controlled bypass thermostat (1) and attached hoses (2) by loosening clamps.

If vehicle is equipped with windshield washer container mounted on left fender well, disconnect electrical connector and fluid line at container, then remove two nuts securing it to body and remove container.

1. Controlled bypass thermostat 2. Coolant hoses

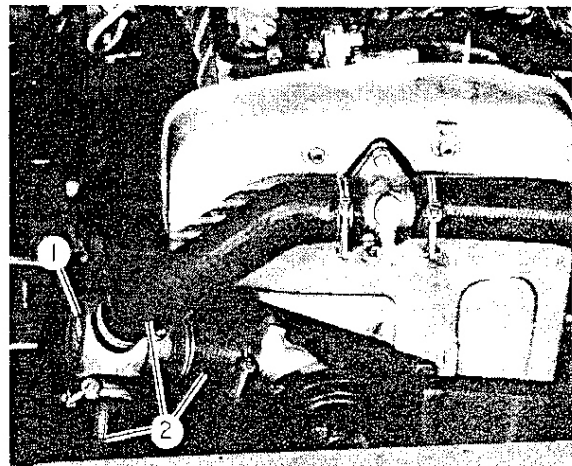

Raise vehicle on lift.

On vehicles without turbocharger, bend locking tabs back and remove nuts securing exhaust pipe to exhaust manifold.

Remove bolt (1) holding exhaust pipe (2) to bracket (3) as shown. Remove bolt (4) and nut (5) holding bracket to transmission.

Pull exhaust pipe away from exhaust manifold.

1. Bolt 2. Exhaust pipe 3. Bracket 4. Bolt 5. Nut

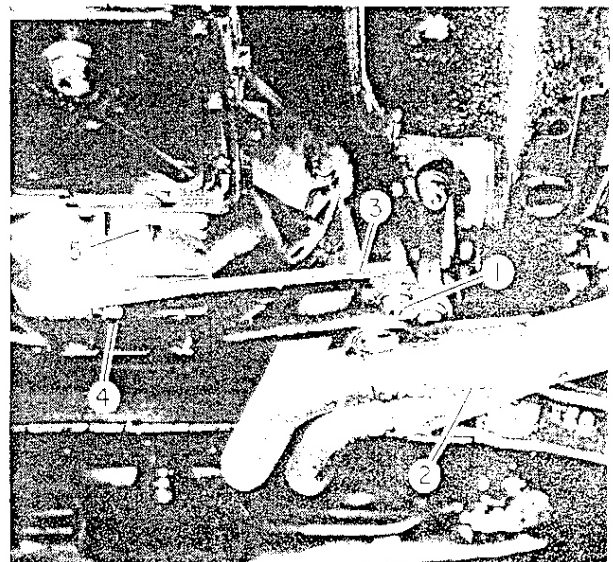

On vehicles with turbocharger, remove 4 nuts (2) and allen bolts (4) holding exhaust pipe (1) to exhaust elbow (3).

Remove bolt holding exhaust pipe to bracket as shown in figure. Remove bolt and nut holding bracket to transmission.

Pull exhaust pipe away from exhaust elbow.

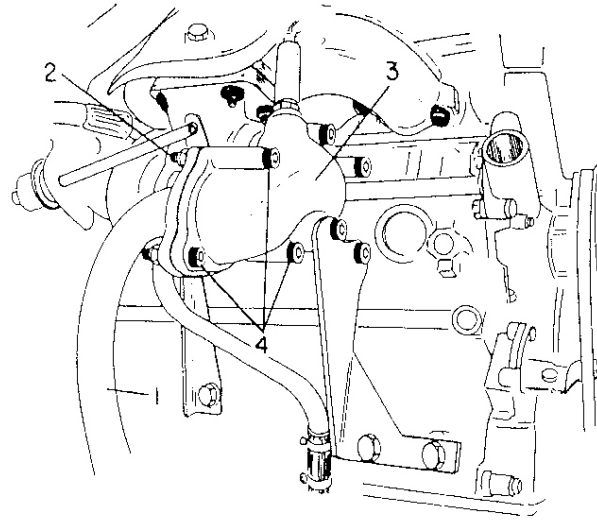

1. Exhaust pipe 2. Nuts 3. Exhaust elbow 4. Bolts

Remove starter (refer to Electrical Section).

Remove four bolts (7) holding flywheel inspection cover (6) to bellhousing (8).

If equipped with automatic transmission, remove three bolts (5) attaching flywheel (4) to torque converter (3). Engine must be rotated to line bolts up with inspection cover opening.

After removing bolts, push converter free from crankshaft as far back as it will go.

CAUTION: During engine removal be sure converter stays on transmission and does not slide forward and fall off.

Using special tool A.55035 or U-joint socket with long extension, remove four bolts (2) attaching bellhousing (8) to engine.

1. Protection plate 2. Bolt 3. Torque converter 4. Flywheel 5. Bolt 6. Inspection cover 7. Bolt 8. Bellhousing

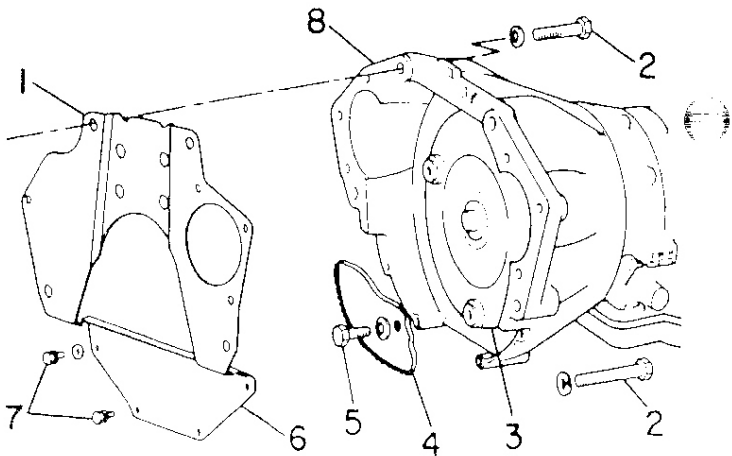
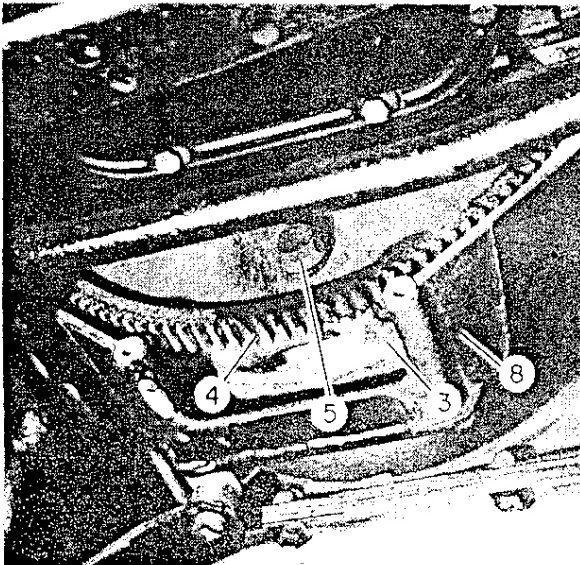

Remove two engine mount nuts thru openings in crossmember (arrow).

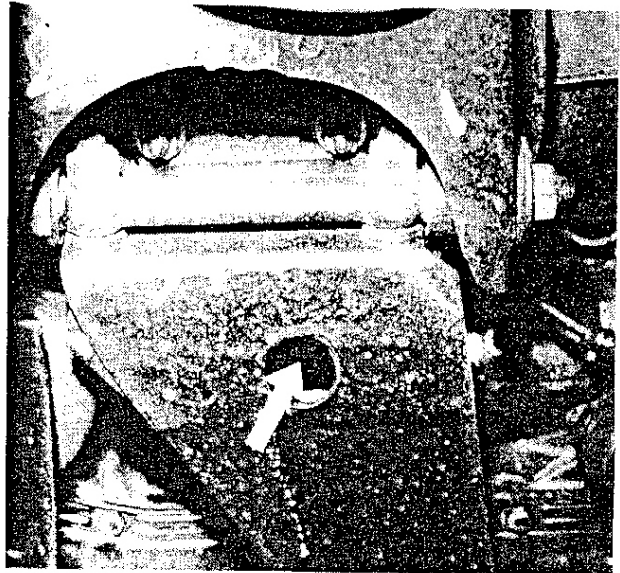

10

Lower vehicle and position floor jack under transmission.

Attach engine lift sling (1). Front lift bracket is attached to engine. For rear attach point, head bolt must be removed and lift bracket secured to it.

NOTE: To ease removal, provide slings of two different lengths to give upward tilt to front of engine as shown.

Lift engine until mount bolts clear crossmember. Move engine forward and up.

With manual transmission, clutch has to clear transmission main shaft, and engine must be moved forward more than with the automatic transmission (raising manual transmission slightly with floor jack will aid in engine removal).

Installation is reverse of removal. Bleed cooling system (refer to Cooling in this section).

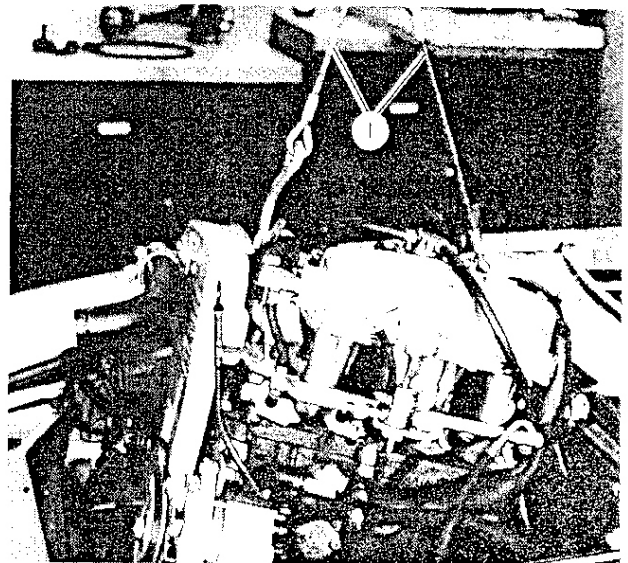

1. Engine lift sling

DISASSEMBLY

Drain oil.

Remove two side mounts with rubber pads from crankcase.

Scribe index marks on clutch (2) and flywheel (1). Remove six bolts (3) and washers holding clutch to flywheel. Remove clutch.

1. Flywheel 2. Clutch 3. Bolts

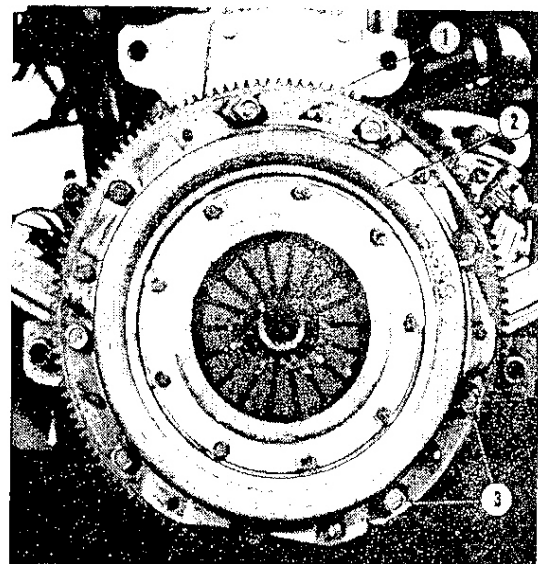

Remove nut on alternator tensioner bolt (1) and mounting bolt (3), then remove belt (4) and alternator (2).

Remove one bolt to remove tensioner bracket (5).

1. Tensioner bolt 2. Alternator 3. Mounting bolt 4. Belt
5. Tensioner bracket

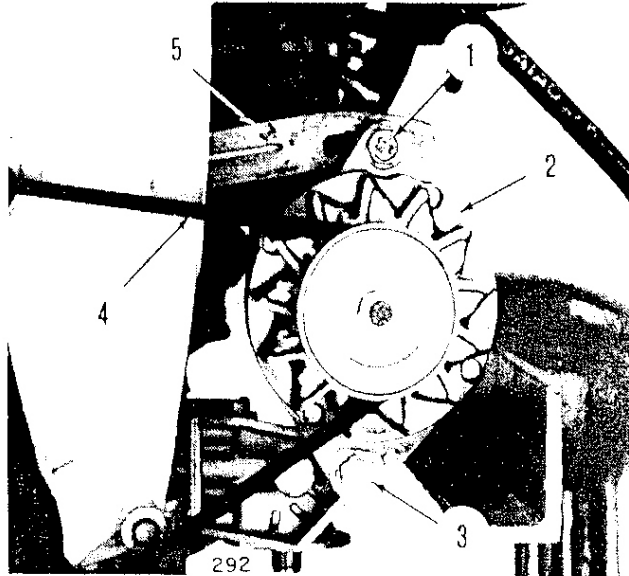

On engines with air pump, remove hose from rear of air pump.

Remove air pump mounting bolt (5) and mounting bolt for tensioner bracket (2).

Remove belt (3) and air pump (6) with attached tensioner bracket (2).

Remove two nuts to remove support bracket (4).

1. Tensioner nut 2. Tensioner bracket 3. Belt 4. Support bracket
5. Mounting bolt 6. Air pump

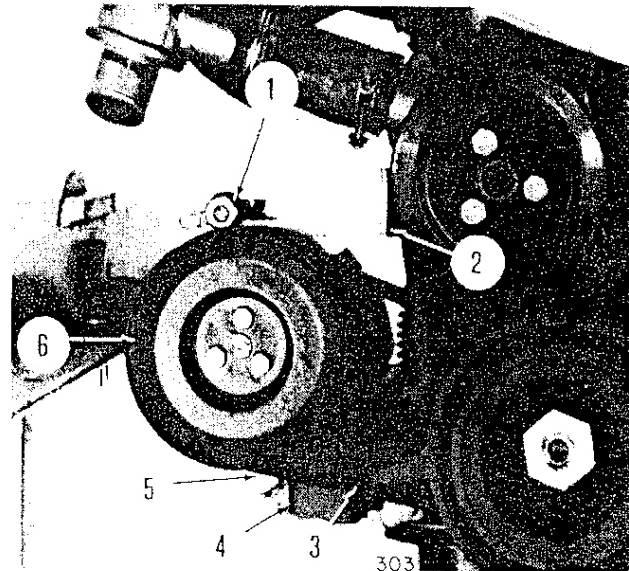

Loosen clamp (8) and disconnect hose.

Remove two bolts (3) and washers, then remove union (2), gasket and attached hoses (9).

Remove two bolts (4) and two nuts (1) to remove timing belt cover (5).

Remove three water pump pulley bolts (6) and remove water pump pulley (7).

1. Nut 2. Union 3. Bolt 4. Bolt 5. Timing belt cover 6. Bolt
7. Pulley 8. Clamp 9. Hoses

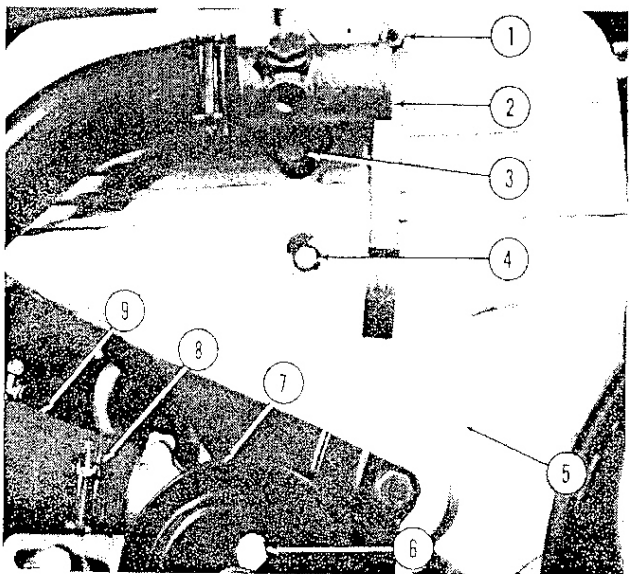

10

Manually turn engine until holes in camshaft sprockets align with timing pointers.

Block flywheel against turning.

Remove nut (4) holding crankshaft pulley (3). Use 38 mm socket. Remove pulley.

Remove four bolts (2, 5 and 8) and two nuts (1 and 6) holding lower sheet metal timing cover (7). Remove cover.

1. Nut 2. Bolt 3. Crankshaft pulley 4. Nut 5. Bolt 6. Nut
7. Timing belt cover 8. Bolt

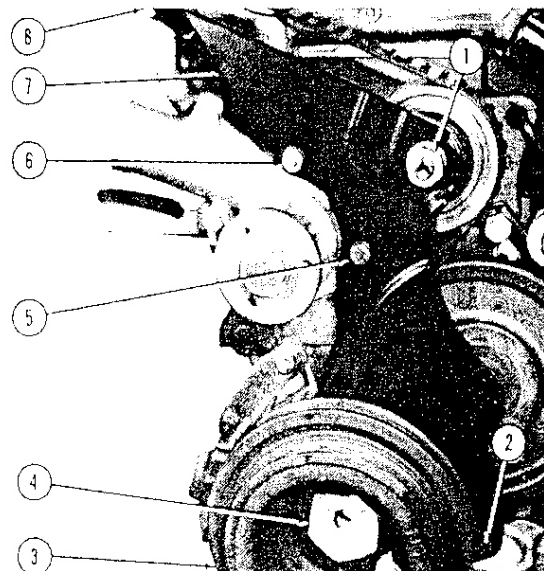

Remove bracket bolt for oil dipstick tube (1). Remove tube.

Remove spacer (3) from tensioner pulley stud. Loosen bolt (2) for tensioner bracket. Pry pulley to release belt tension. Retighten bolt (2) to hold pulley in belt-slackened position. Remove timing belt (4). Discard belt.

1. Oil dipstick tube 2. Bolt 3. Spacer 4. Timing belt

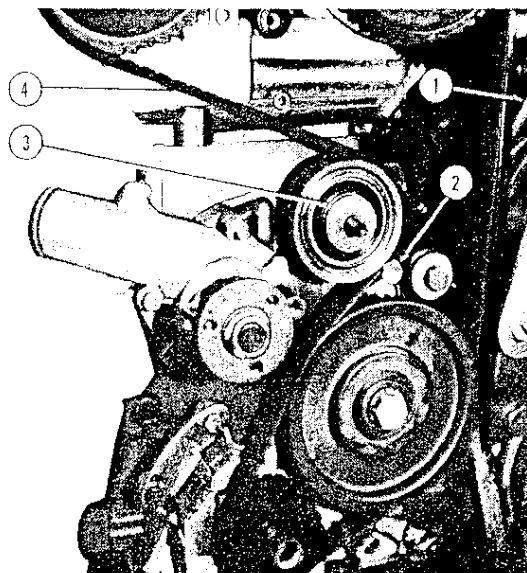

Loosen bolt (7) for tensioner bracket (3) to relieve tension from spring (2).

CAUTION: Spring is under high tension.

Remove spring from hole (1) in tensioner bracket.

Remove spring retaining bolt (4). Remove spring. Remove tensioner bracket bolt. Slide off tensioner bracket with pulley (10).

Remove bolt (6) and washer holding sprocket (5) on auxiliary shaft. Hold sprocket with used timing belt. Remove sprocket.

Remove four bolts (8) and washers holding water pump (9). Remove pump and gasket.

1. Hole 2. Spring 3. Tensioner bracket 4. Spring retaining bolt
5. Sprocket 6. Bolt 7. Bolt 9. Water pump 10. Pulley

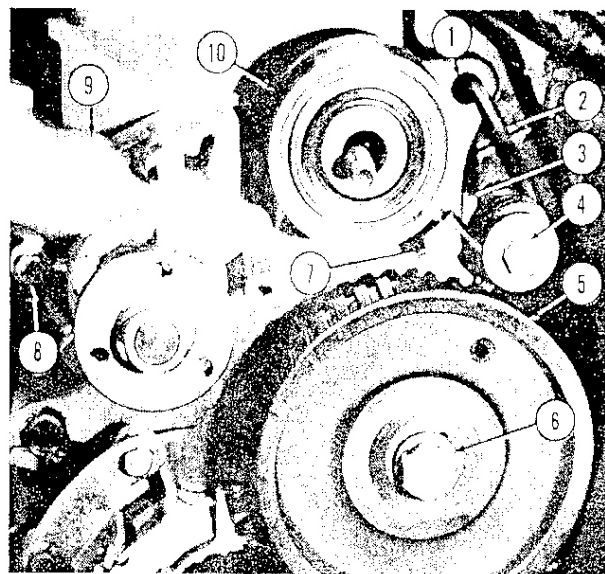

Remove top bolt (1).

Remove intake manifold bolt (2) holding rear timing belt cover (3) to manifold. Remove rear timing belt covers.

1. Bolt 2. Intake manifold bolt (behind cover) 3. Rear timing belt covers

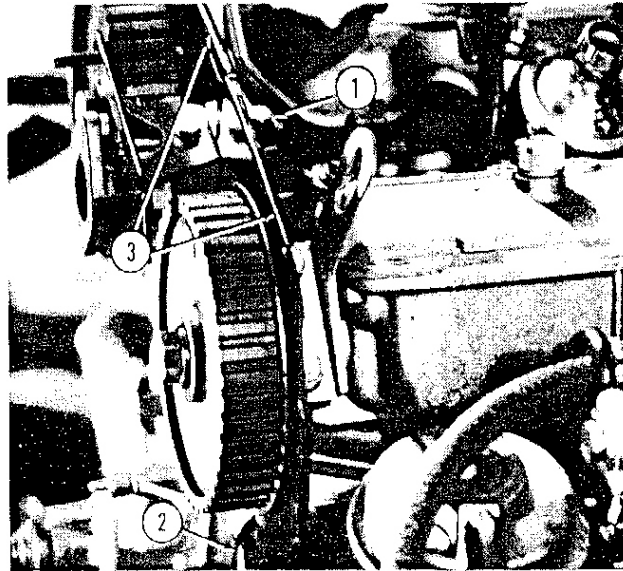

Loosen clamp (3), then disconnect water hose (4) from heater tube (2).

Remove nut holding clamp on heater tube (2) to exhaust manifold.

Remove ten cylinder head bolts (1) and washers. Remove entire cylinder head assembly and gasket.

Disassemble head as specified in section 101.01.

1. Bolt 2. Heater tube 3. Clamp 4. Water hose

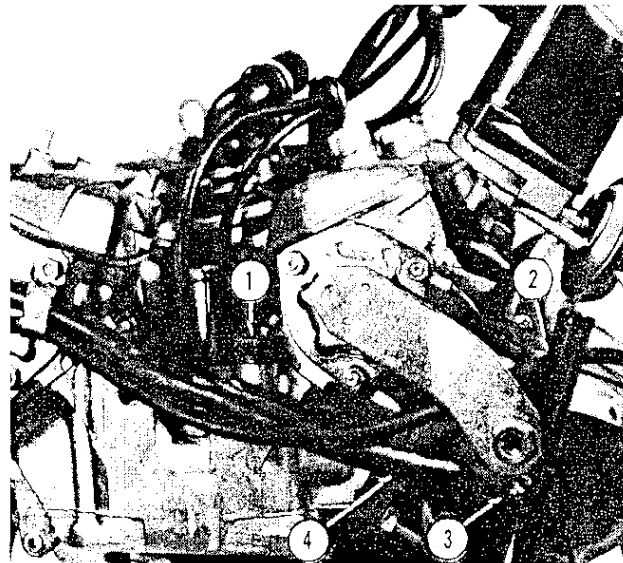

Loosen clamps (8) on oil vapor hose (7), then remove hose.

Remove bolt (2) and washer retaining oil vapor separator (1). Remove separator.

Remove four oil filter support bolts. Remove oil filter support (6) and gasket.

Remove two fuel pump bolts (4). Remove fuel pump (3), spacer (5) and two gaskets (carburettored engines).

1. Oil vapor separator 2. Bolt 3. Fuel pump 4. Bolt 5. Spacer
6. Oil filter support 7. Oil vapor hose 8. Clamp

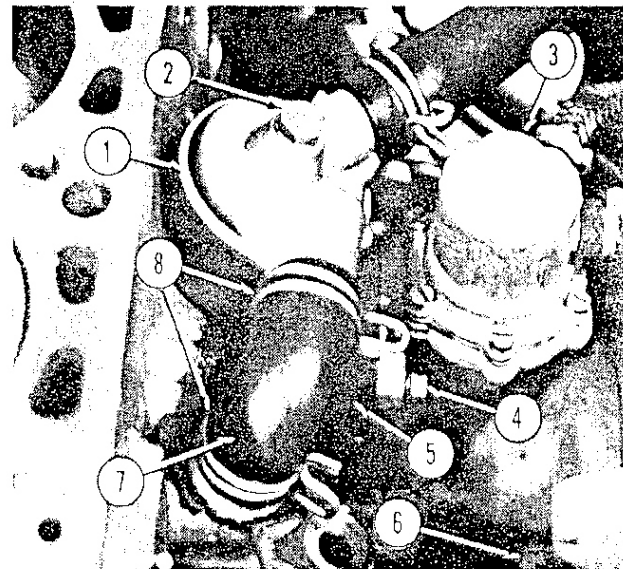

Remove three bolts, nut, and washers holding cover for auxiliary shaft. Remove cover and gasket. Remove nut, washer, and clamp holding spacer for oil pump gear (1) in crankcase.

Remove spacer and gasket. Rotate auxiliary shaft to raise oil pump gear. Using thin pliers, remove gear (1). Remove two bolts (2) and washers holding retainer (3) for auxiliary shaft (4). Remove retainer. Pull auxiliary shaft (4) out of crankcase.

1. Gear 2. Bolts 3. Retainer 4. Auxiliary shaft

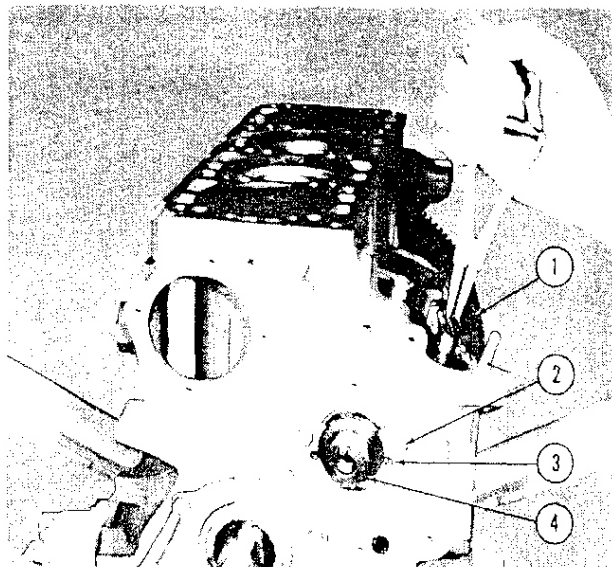

Remove 18 bolts and washers holding oil sump. Remove sump and gasket.

Remove five bolts (3) and washers holding cover (2) for crankcase. Remove cover (2).

Remove two bolts (6) and washers holding oil pump (1). Remove pump (1) and gasket.

Remove two bolts (4) and washers holding oil tube (5). Remove tube.

1. Oil pump 2. Cover 3. Bolts 4. Bolts 5. Oil tube 6. Bolt

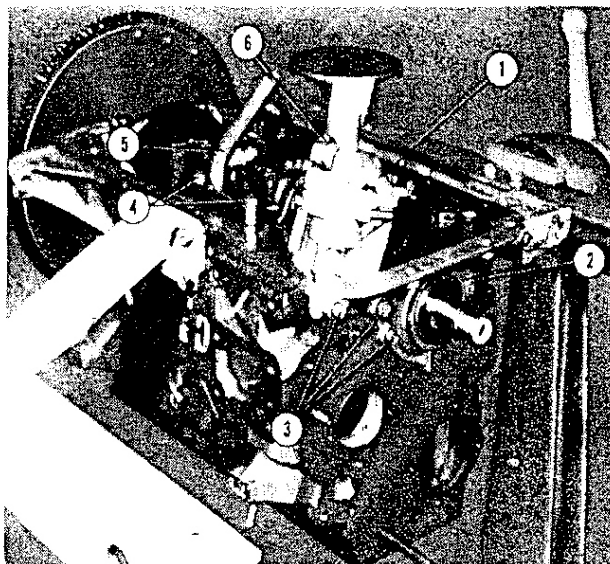

Remove two nuts (1) and washers holding end cap (2) on connecting rod. Remove cap and bearing insert. Turn crankshaft until piston being removed is at T.D.C. Remove piston and reassemble cap and nuts to connecting rod. Repeat for remaining pistons one at a time.

Remove six bolts and washer plate holding flywheel (3) on crankshaft. Remove flywheel.

1. Nut 2. Cap 3. Flywheel

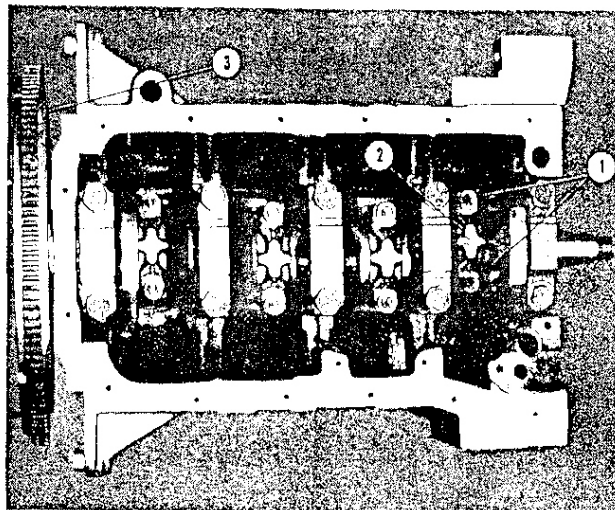

Remove six bolts and washers holding rear cover for crankshaft. Remove cover and gasket.

Remove pilot bearing (3) from crankshaft. Use tool A.40206, A40207, and slide hammer puller.

Remove 10 bolts holding main bearing caps. Remove caps and bearing inserts.

Remove crankshaft, bearing inserts, and thrust rings.

1. Slide hammer puller 2. Tool 3. Pilot bearing

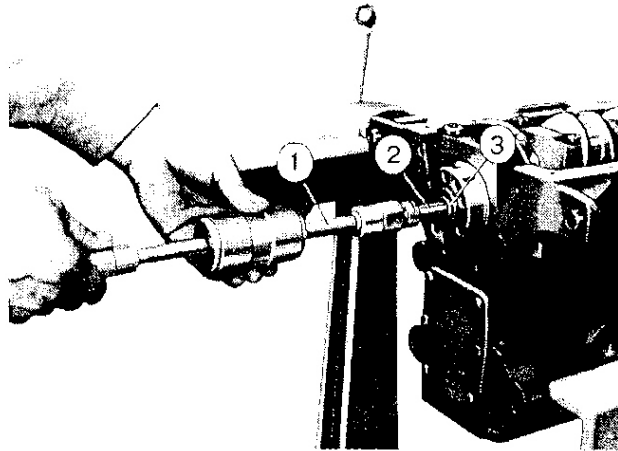

ASSEMBLY

Install crankshaft. Refer to 101.03. Make sure number on caps is same as number on crankcase. Make sure caps are installed at proper location. Cap without notch is at front of crankcase. Then cap with one notch, etc.

Install pistons. Refer to Section 101.05.

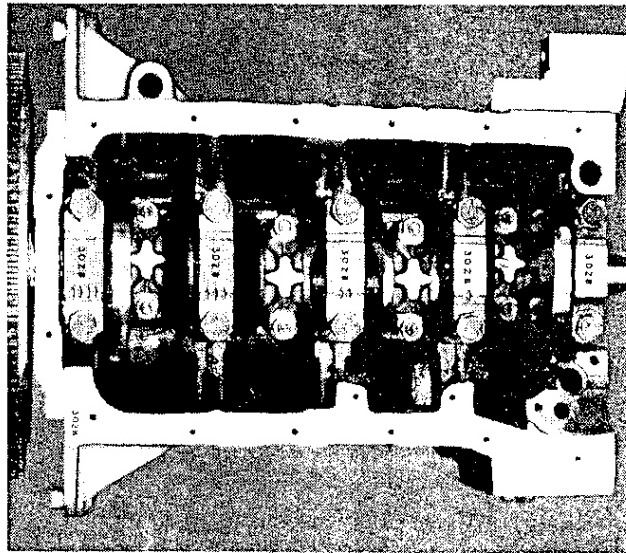

Install bearing for input shaft in seat in crankshaft rear end. Fit oil seal in rear cover for crankshaft. Install cover with six bolts and washers.

Rotate crankshaft until crankpins for No. 1 and No. 4 cylinders are at T.D.C. (crankpins should be at top). Position flywheel on crankshaft with index mark facing 1 and 4 crankpins.

Secure flywheel to crankshaft with washer plate and six bolts. Lock crankshaft against turning. Torque bolts to 105 ft. lbs. (14.5 kgm).

1. Holding tool 2. Socket 3. Bolt 4. Torque wrench

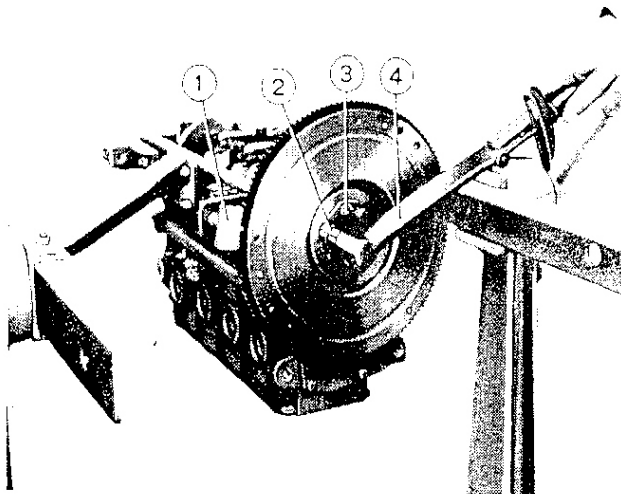

Lubricate bushings for auxiliary shaft with oil. Install auxiliary shaft. Secure shaft with retaining plate, two bolts, and washers. Place gasket, oil seal and cover (1) on auxiliary shaft (4). Secure cover with three bolts (3), nut (2) and washers. Place oil pump drive gear in crankcase. Place spacer on gear.

1. Cover 2. Nut 3. Bolts 4. Auxiliary shaft

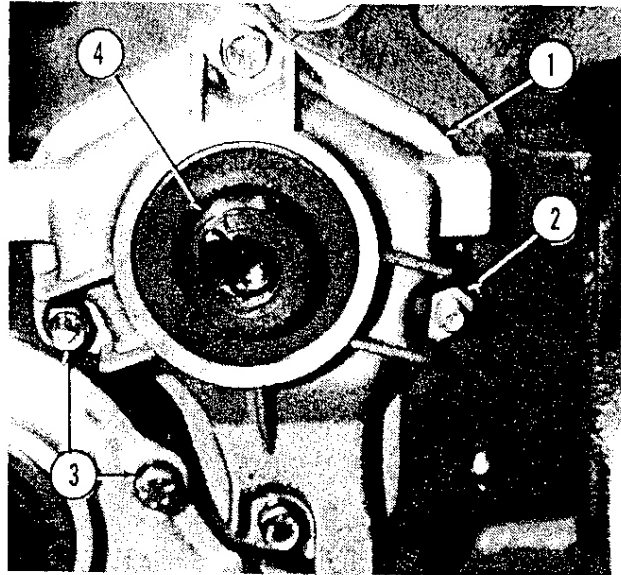

Place auxiliary shaft sprocket (1) onto shaft. Rotate auxiliary shaft until gear seats. Secure spacer with clamp, washer and nut.

Place oil pump (2) with pickup tube, gasket and drive gear in crankcase. Start bolts (3) thru pump.

Turn auxiliary shaft while tightening bolts securing oil pump.

Install oil line for breather with two bolts and washers in crankcase.

Install oil sump.

1. Auxiliary shaft sprocket 2. Oil pump 3. Bolts

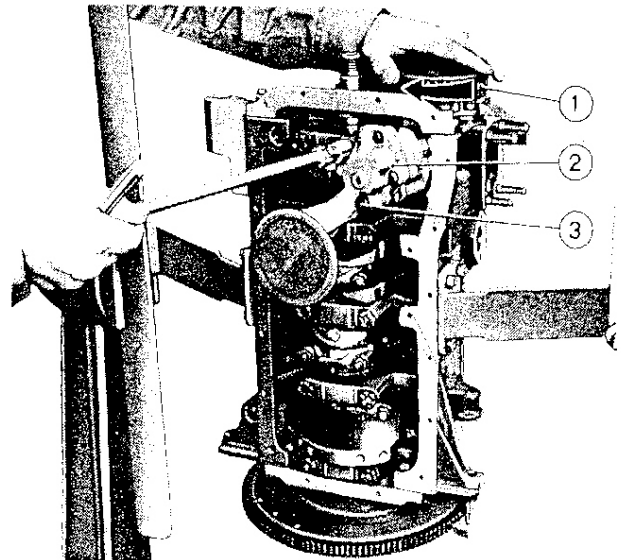

Install two bolts (4), washers, gasket, spacer (5) gasket and fuel pump (3) (carburettored engines).

Install gasket, oil filter support (6) and four bolts.

Install separator (1) and bolt (2). Install oil vapor hose (7) and clamps (8).

1. Oil vapor separator 2. Bolt 3. Fuel pump 4. Bolt 5. Spacer
6. Oil filter support 7. Oil vapor hose 8. Clamp

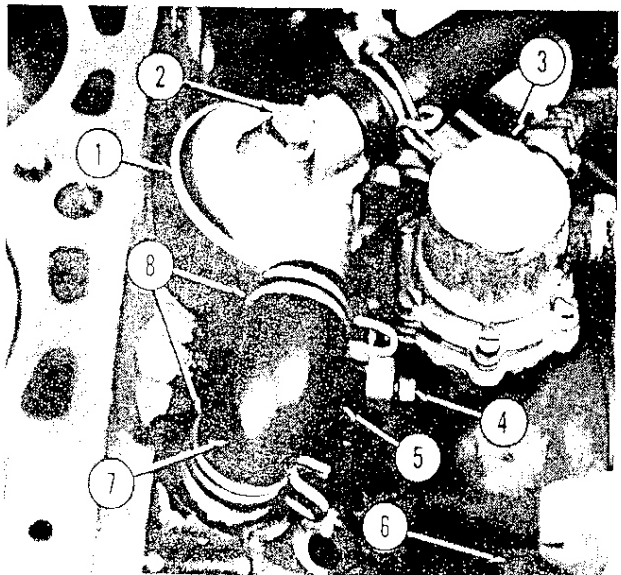

Lubricate cylinder bores, then turn crankshaft until No. 4 cylinder is at top center.

Place cylinder head gasket on block. Make sure word "ALTO" is up.

Check that cam sprocket timing marks are aligned with pointers on cam housing, then place cylinder head on block.

Install ten bolts and washers thru cylinder head. Tighten as shown in two steps; 29 ft. lbs. (4 kgm), 61 ft. lbs. (7.5 kgm).

Connect hose from carburetor choke to heater tube. Secure with clamp (carburetored engines).

Attach clamp on heater hose to exhaust manifold stud.

Slide crankshaft pulley on crankshaft. Check that crankshaft pulley timing mark aligns with T.D.C. (longest pointer on timing scale).

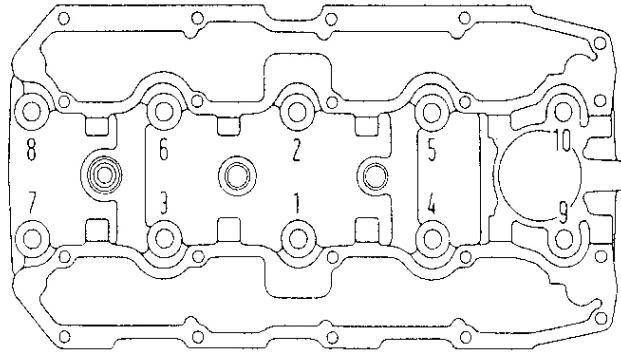

Install rear timing belt covers (3). Install bolt (2) holding cover to intake manifold. Install top bolt (1).

1. Top bolt 2. Bolt (behind cover) 3. Rear timing belt covers

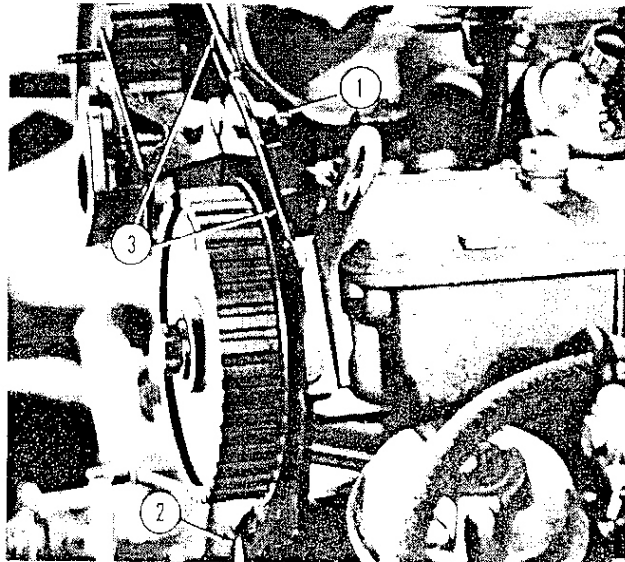

Place water pump (6) and gasket on crankcase. Secure pump with four bolts (5) and washers.

Install sprocket (4) and bolt on auxiliary shaft. Using old timing belt to hold sprocket, torque bolt to 87 ft. lbs. (12 kgm). Install tensioner bracket (1) with pulley and tensioner bracket bolt. Install spring and spring retaining bolt (2). Place spring in hole in tensioner bracket.

CAUTION: Spring is under high tension when set.

Turn auxiliary shaft sprocket to align hole (3) in sprocket with spring retaining bolt (2).

1. Tensioner bracket 2. Spring retaining bolt 3. Hole 4. Sprocket 5. Bolt 6. Water pump

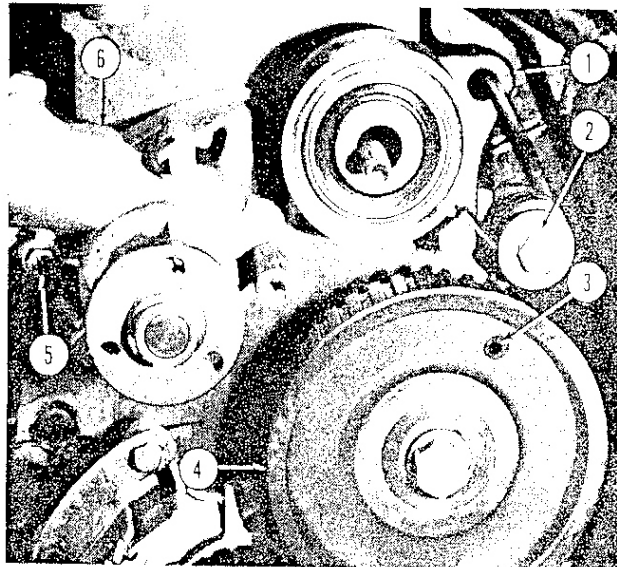

With tensioner bracket bolt (4) slightly loose, pry tensioner pulley (11) to belt-slackened position and tighten tensioner bracket bolt.

Wrap new timing belt (12) over crankshaft sprocket (8), auxiliary shaft sprocket (9), intake camshaft sprocket (2) and exhaust camshaft sprocket (1).

Make sure all play is between exhaust camshaft sprocket (1) and tensioner pulley (11).

Place timing belt over tensioner pulley. Loosen tensioner bracket bolt (4) and allow tensioner pulley to take out play. DO NOT apply additional force to tensioner pulley.

Turn crankshaft two full turns. Check that timing is correct, then tighten tensioner bracket bolt.

Install spacer (10) on tensioner pulley stud. Install oil dipstick tube (3) and bracket bolt.

1. Exhaust camshaft sprocket 2. Intake camshaft sprocket 3. Oil dipstick tube 4. Tensioner bracket bolt 5. Spring retaining bolt 6. Hole 7. Bolt 8. Crankshaft sprocket 9. Auxiliary shaft sprocket 10. Spacer 11. Tensioner pulley 12. Belt

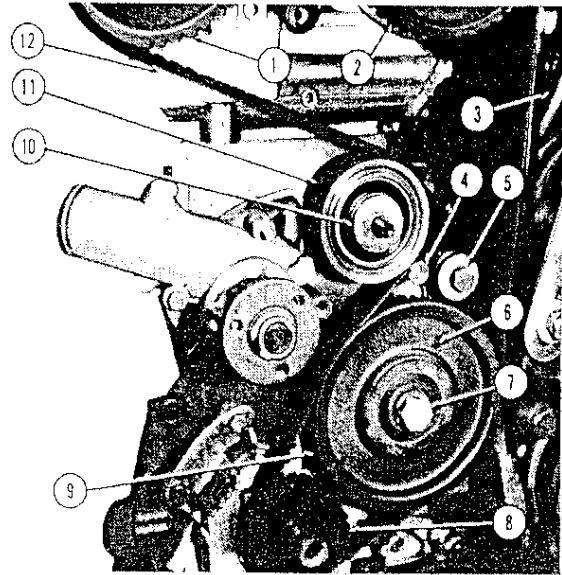

Install lower sheet metal timing belt cover with four bolts (2, 5 and 8) and two nuts (1 and 6). Torque nut (1) to 33 ft. lbs. (4.5 kgm).

Coat crankshaft pulley (3) inside diameter with anti-seize compound. Place pulley on crankshaft. Secure pulley with nut (4). With flywheel blocked, torque nut to 181 ft. lbs. (25 kgm).

1. Nut 2. Bolt 3. Crankshaft pulley 4. Nut 5. Bolt 6. Nut 7. Timing belt cover 8. Bolt

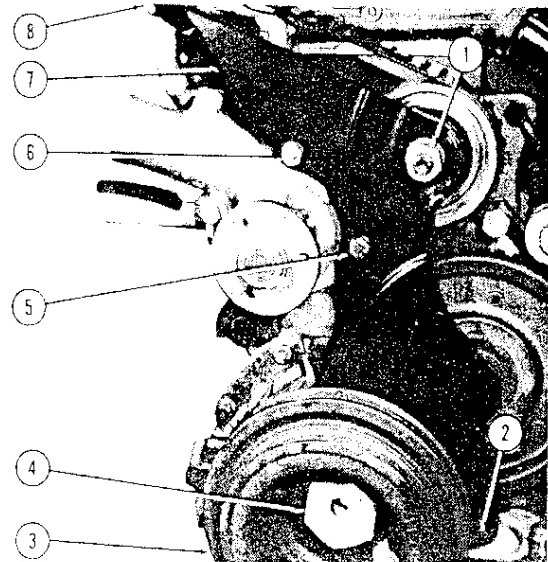

Install water pump pulley (7) and three bolts (6).

Install timing belt cover (5) and retain with two bolts (4) and two nuts (1).

Install union gasket, union (2) and two bolts (3) and washers.

Connect hose and tighten clamp (8).

1. Nut 2. Union 3. Bolt 4. Bolt 5. Timing belt cover 6. Bolt 7. Water pump pulley 8. Clamp 9. Hoses

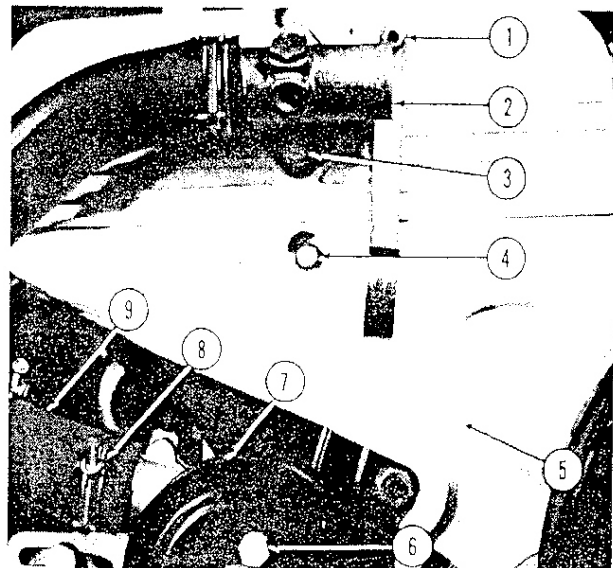

On engine with air pump, install air pump support bracket (4) using two nuts. Tighten nuts to 20 ft. lbs. (2.8 kgm).

Using mounting bolt (5) and bolt for tensioner bracket (2), install air pump (6). Tighten bolt for tensioner bracket to 38 ft. lbs. (52 ft. lbs. for Znt/EC coating*).

Install belt (3). Adjust belt tension, then tighten tensioner nut (1) to 18 ft. lbs.

Tighten mounting bolt (5) to 38 ft. lbs.

*Znt/EC coated components are olive green colored.

1. Tensioner nut 3. Tensioner bracket 3. Belt 4. Support bracket
5. Mounting bolt 6. Air pump

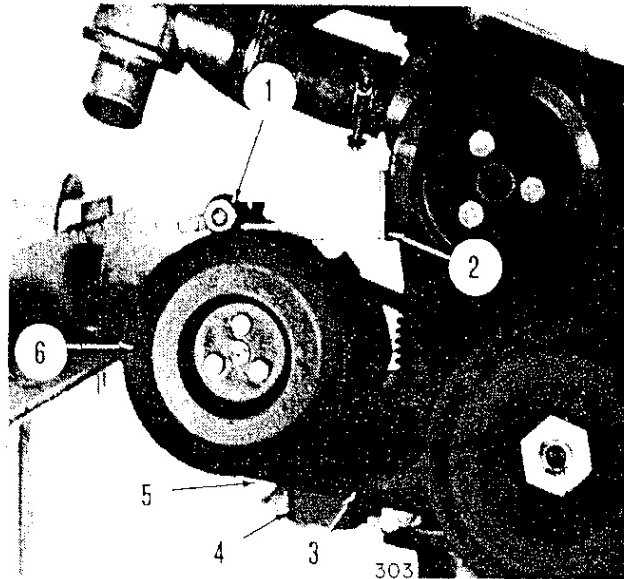

Install tensioner bracket (5). Tighten nut to 51 ft. lbs. (7.05 kgm).

Using alternator mounting bolt (3) and tensioner bolt (1), install alternator (2).

Install belt (4). Adjust belt tension, then tighten nut for tensioner bolt to 32 ft. lbs. (4.4 kgm).

Tighten mounting bolt to 51 ft. lbs. (7.05 kgm).

1. Tensioner bolt 2. Alternator 3. Mounting bolt 4. Belt
5. Tensioner bracket

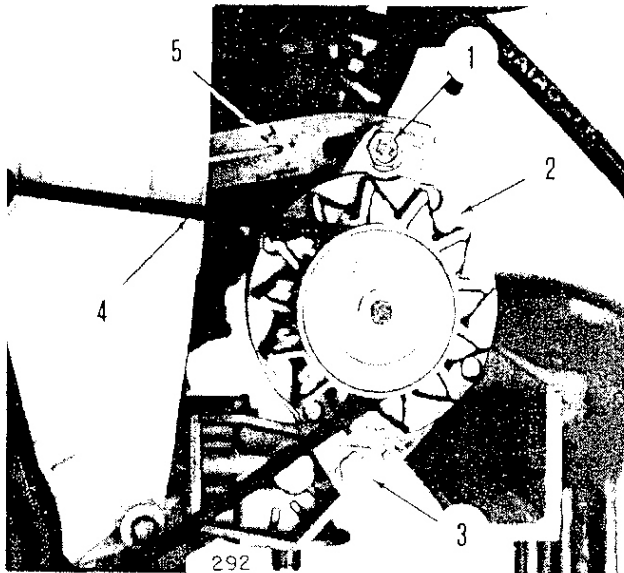

Place protruding part of clutch disc away from flywheel (1).

Align scribe marks on clutch pressure plate (2) with scribe mark on flywheel (1).

Install six bolts (4) finger tight.

Install clutch centering tool (3) A.70081, then fully tighten bolts (4).

Attach engine to crane. Remove support arms. Install two side mounts with rubber pads on crankcase.

1. Flywheel 2. Clutch pressure plate 3. Clutch centering tool
4. Bolt

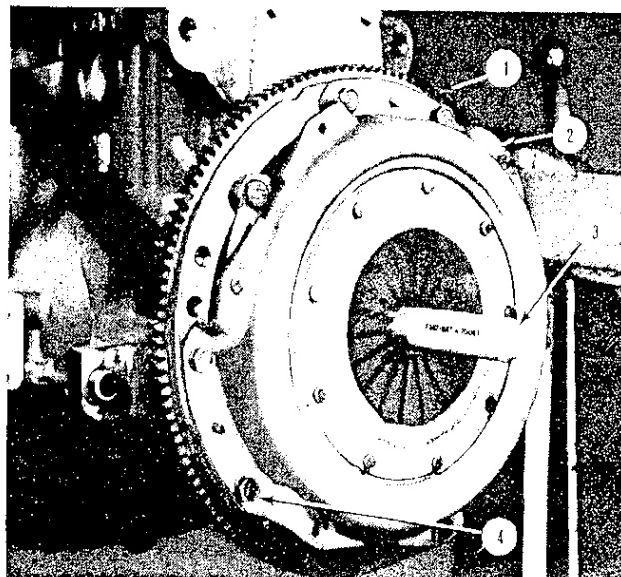

CRANKCASE

CHECKING CYLINDER BORES

Carefully examine cylinder bore surface. If only slight scoring or scratches are found, dress bores. Use extra fine emery cloth wrapped around a hone. Zero dial indicator (1) using ring gauge A.96146 (2).

- 1. Dial indicator
- 2. Ring gauge A.96146

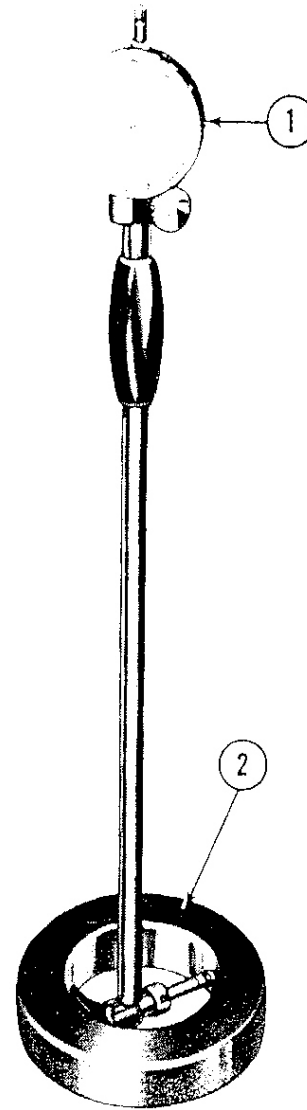

Check cylinder bore at three points both lengthwise and cross wise.

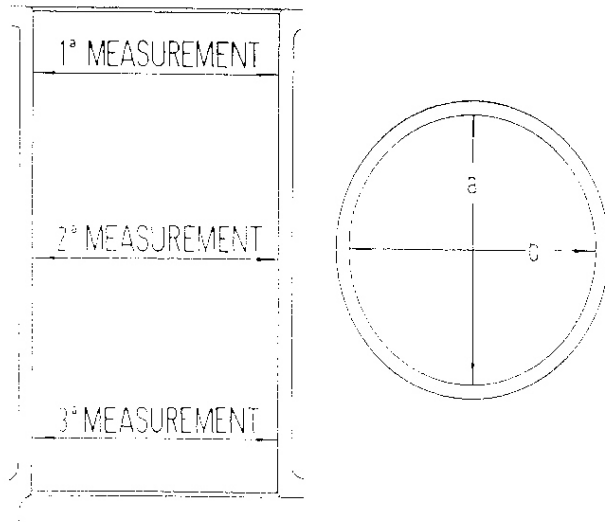

101

The bore class is indicated by letters stamped on the bottom of crankcase (indicated by arrows).

Cylinder bore diameter may vary from 3.3070 to 3.3090 inches (84.000 to 84.050 mm).

Bores are selected in 0.004 inch (0.01 mm) classes.

A = 84.000 – 84.010 mm

C = 84.020 – 84.030 mm

E = 84.040 – 84.050 mm

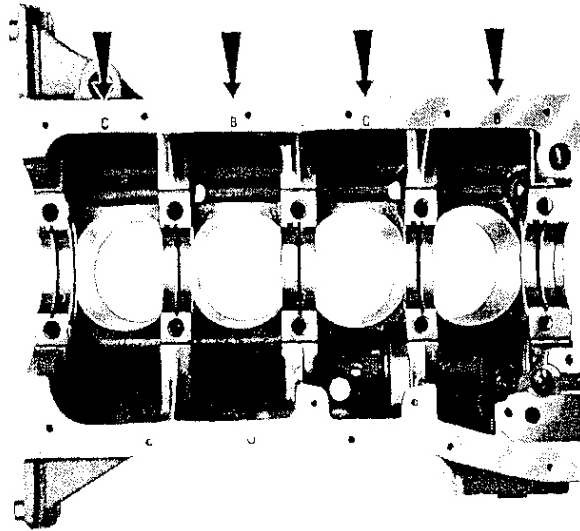

CYLINDER HEAD (Carbureted)

REMOVAL AND INSTALLATION (Engine in Vehicle)

Disconnect battery ground cable located in trunk. Loosen fuel tank filler cap to release any fuel pressure.

Drain radiator thru plug on lower left side of radiator. Drain engine coolant thru plug in lower right side of block.

Remove three nuts (1) holding air cleaner top cover (2). Remove all air and vacuum lines to air cleaner.

Remove four nuts holding air cleaner to carburetor. Lift air cleaner up high enough to remove lines underneath. Remove air cleaner assembly (3) and all attached lines.

1. Nut 2. Air cleaner top cover 3. Air cleaner assembly

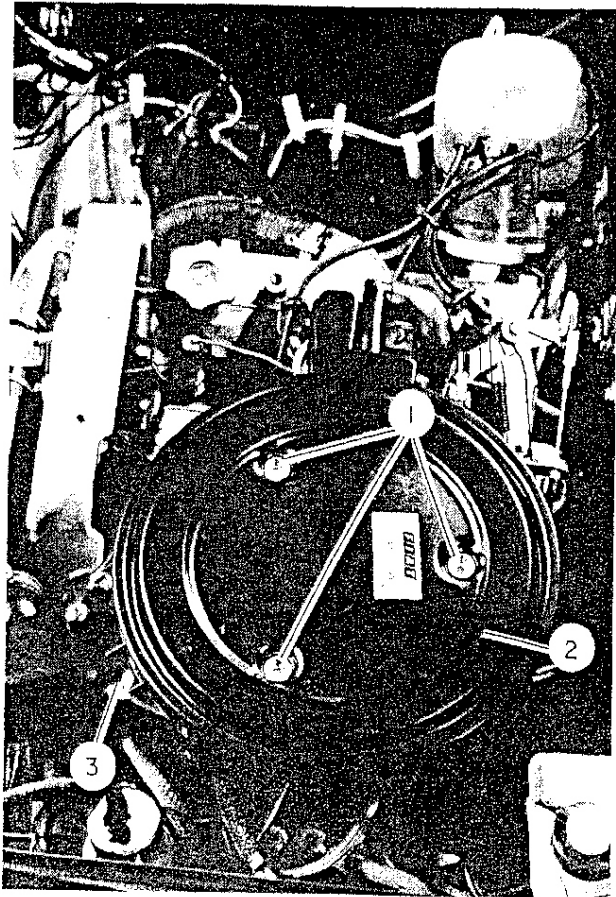

On left side of engine, mark to identify, then remove fuel inlet line (1), fuel return line (2), fuel vapor line (3), EGR line (4), power brake vacuum line (5), purge tank vacuum line (6), gulp valve vacuum lines (7) and carburetor electrical connector (8).

Disconnect throttle rod (9) at carburetor. Remove two nuts attaching linkage (10) to camshaft cover, and lay linkage to one side.

Remove bolt holding oil dipstick assembly (12) to intake manifold.

Disconnect vacuum line from intake manifold to automatic transmission, if equipped with automatic transmission.

1. Fuel inlet line 2. Fuel return line 3. Fuel vapor line 4. EGR line
5. Power brake vacuum line 6. Purge tank vacuum line 7. Gulp valve vacuum lines 8. Idle stop solenoid 9. Throttle rod 10. Throttle linkage 11. Engine overheat switch 12. Oil dipstick assembly

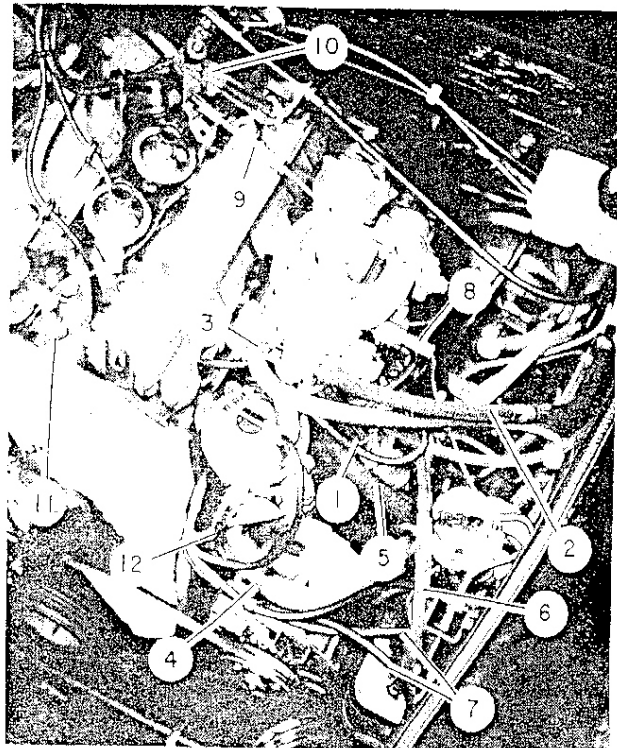

Mark to identify, then disconnect two water temperature electrical connectors (1) from top of cylinder head.

Loosen clamps and remove air hoses (2) from check valve (two reed valves for engines without air pump). Loosen clamp and remove heater hose (3).

If equipped with automatic transmission, remove bolt holding dipstick assembly to rear of right cam housing.

On vehicles with electronic ignition (1979 and on), disconnect white distributor lead wire from electronic control module mounted on right fender shield. Disconnect black ground wire from module, at rear of cylinder head.

On vehicles with standard breaker-point ignition (up to 1978), disconnect two wire connectors at distributor.

Disconnect coil high voltage lead (4) from distributor.

1. Water temperature electrical connector 2. Air hoses 3. Heater hose 4. Coil high voltage lead

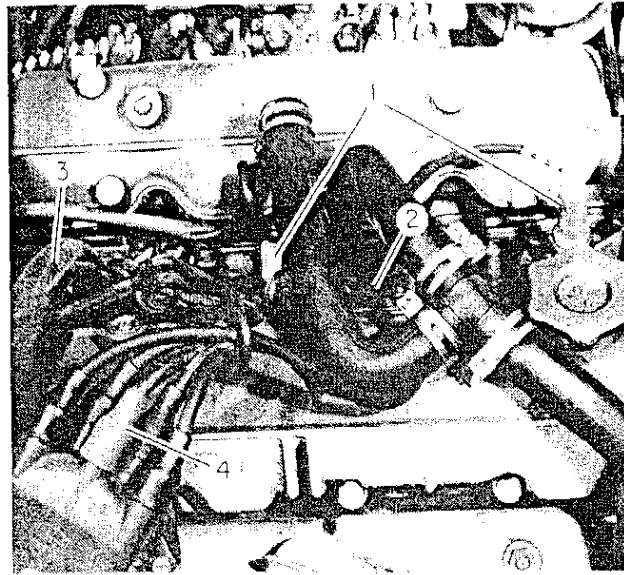

Loosen clamp and remove coolant hose (1) from controlled bypass thermostat (2). Loosen clamp on radiator hose (3) and remove from radiator.

Remove two bolts (4) to remove union (5) and attached hoses.

Remove drive belts from crankshaft pulley.

Remove two nuts (6) and bolts to remove timing belt cover (7).

1. Coolant hose 2. Controlled bypass thermostat 3. Radiator hose
4. Bolt 5. Union 6. Nut 7. Timing belt cover

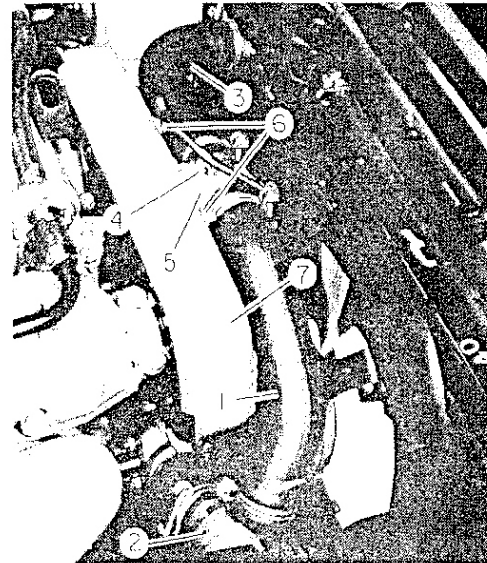

Manually turn engine until holes in camshaft sprockets align with timing pointers.

Block flywheel against turning.

Remove nut (4) holding crankshaft pulley (3). Use 38 mm socket. Remove pulley.

Remove four bolts (2, 5 and 8) and two nuts (1 and 6) holding lower sheet metal timing shield (7). Remove shield.

1. Nut 2. Bolt 3. Crankshaft pulley 4. Nut 5. Bolt 6. Nut
7. Timing belt shield 8. Bolt

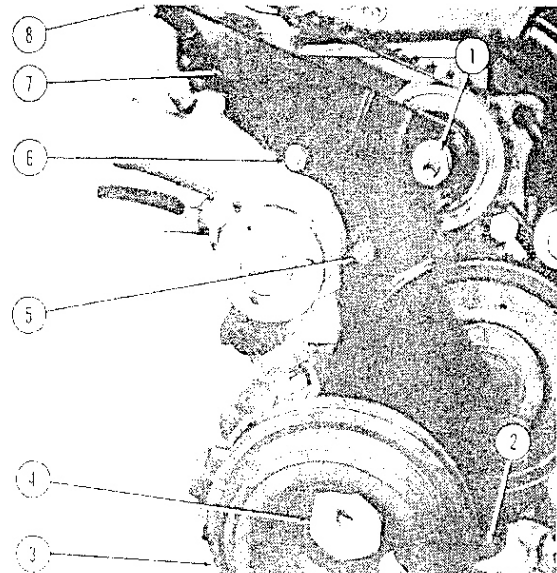

Loosen bolt (3) for tensioner bracket (4). Pry pulley in direction of arrow to release belt tension. Reinstall nut on pulley (1) and tighten it and bolt (3) to hold pulley in belt slackened position.

Remove timing belt (5). Mark belt as "not reusable".

Loosen but do not remove tensioner spring retaining bolt (2).

1. Tensioner pulley 2. Spring retaining bolt 3. Bolt 4. Tensioner bracket 5. Timing belt

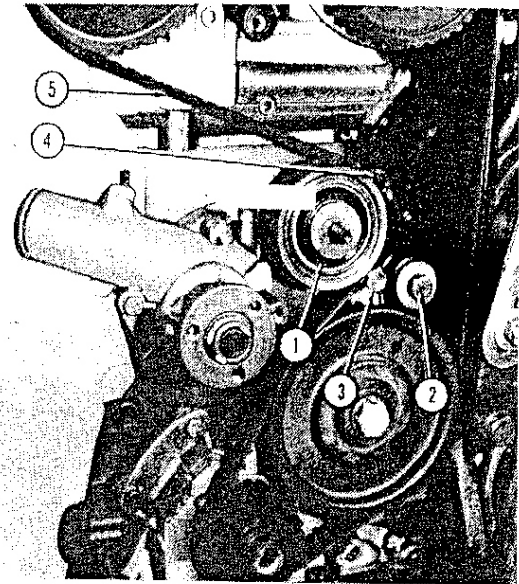

Remove bolts (1 and 2) to remove timing belt shields (3).

1. Bolt 2. Bolt (behind cover) 3. Timing belt shields

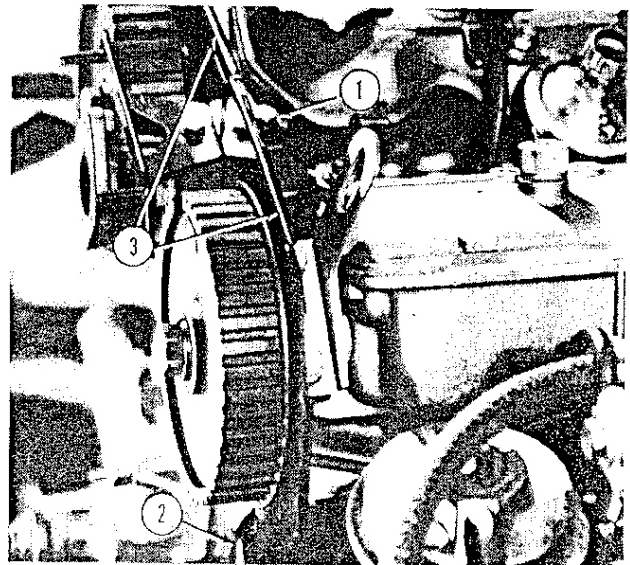

Remove nuts securing exhaust pipe to exhaust manifold (4). Disconnect metal heater line (1) by removing two nuts at flange (2) and one nut (3) on exhaust manifold. Remove ten cylinder head bolts and washers. Remove cylinder head and gasket.

1. Metal heater line 2. Flange 3. Nut 4. Exhaust manifold

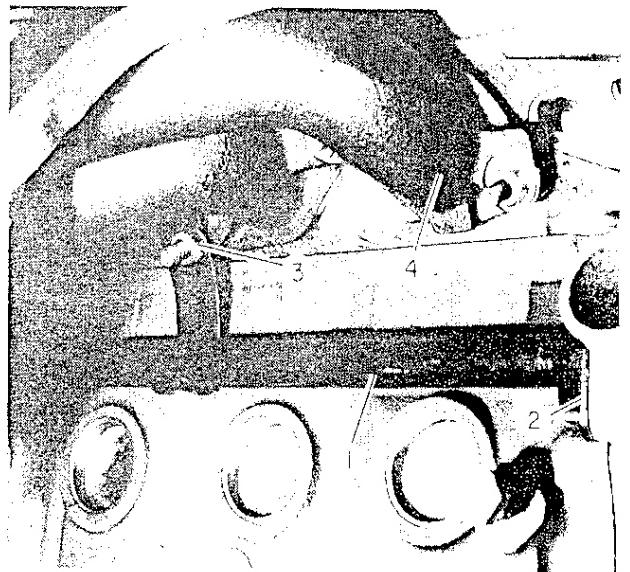

Install cylinder head in reverse order of removal.

Make sure word "ALTO" (top) on head gasket (1) is facing up, and that two guide dowels (2) are in place in cylinder block.

Install timing belt (refer to Camshaft Drive in this section).

Refill and bleed cooling system (refer to Radiator in this section).

Tighten head bolts in order shown. Torque in at least two stages, final torque will be 61 ft lbs (8.5 kgm).

- 1. Cylinder head gasket
- 2. Guide dowel

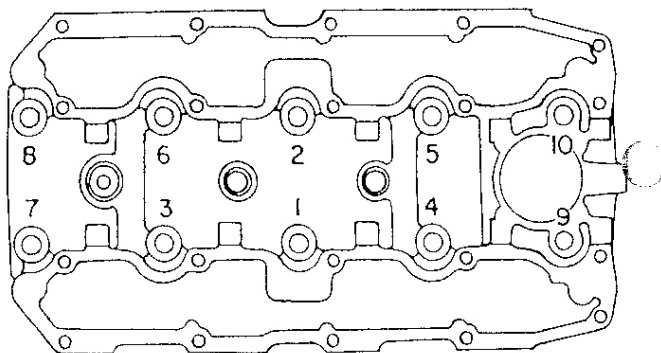
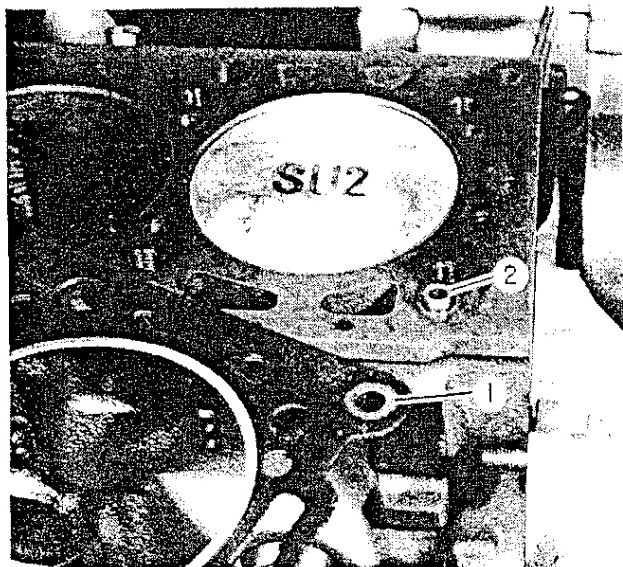

101

CYLINDER HEAD (Fuel Injected and Turbo-Charged)

REMOVAL AND INSTALLATION (Engine in Vehicle)

Disconnect battery ground cable located in trunk.

Loosen fuel tank filler cap to release any fuel pressure.

Drain radiator thru plug in lower left side of radiator. Drain engine coolant thru plug in lower right side of block.

Remove air intake line (1) by loosening three clamps (2).

1. Air intake line 2. Clamp

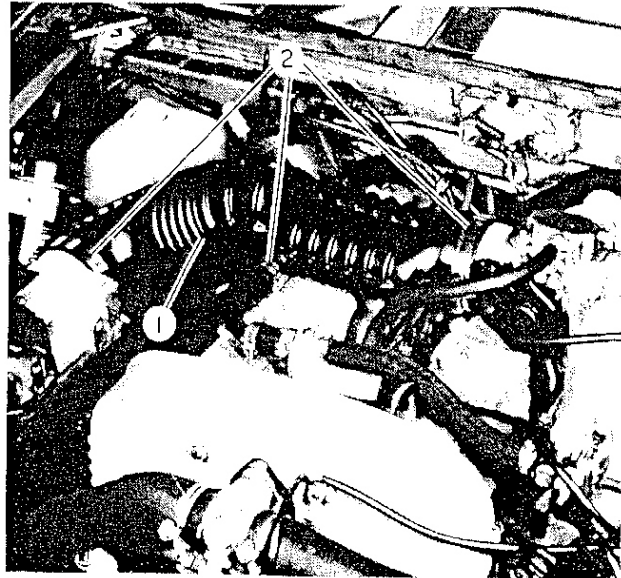

On turbo-charged engines, first remove auxiliary air regulator fitting (1) to compressor discharge plenum (2). Then remove bracket (3) and clamps (4) to remove plenum.

Loosen clamp (5) on air outlet hose (6) to remove hose.

1. Fitting 2. Compressor discharge plenum 3. Bracket 4. Clamp
5. Clamp 6. Compressor air outlet hose

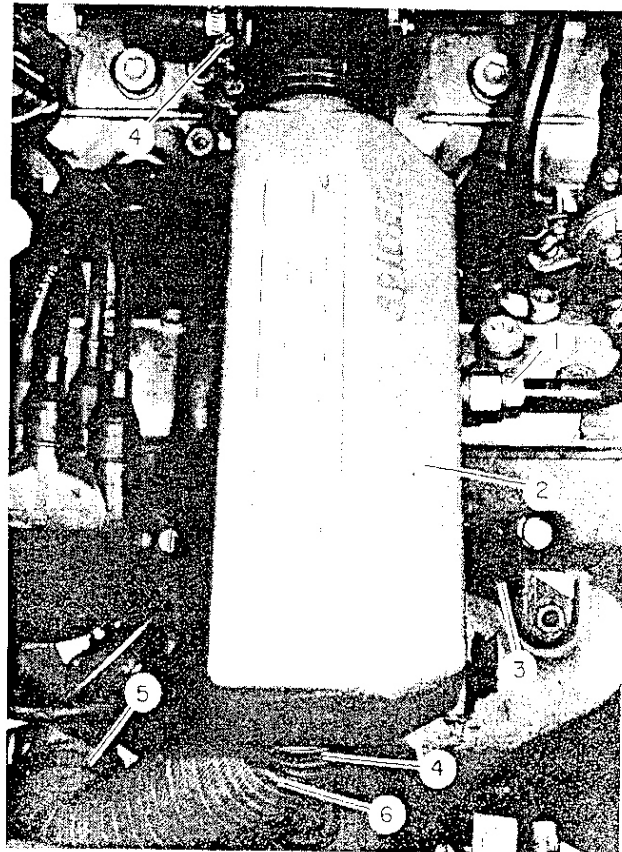

Loosen clamps to remove power brake vacuum line (1) and vapor canister vacuum line (2) from intake manifold fittings. Also disconnect vacuum line to automatic transmission, if so equipped.

Remove bolts and clamps (3) securing wire harness (4) to intake manifold. Disconnect all electrical connectors coming out of harness (pull connectors straight out).

1. Power brake vacuum line 2. Vapor canister vacuum line 3. Clamp
4. Wire harness

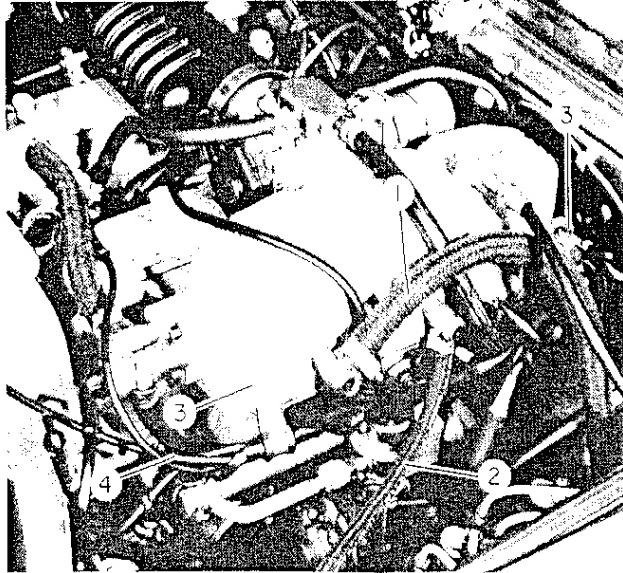

Rotate throttle lever (1) and remove throttle cable (2).

CAUTION: Note for reassembly that both adjustment nuts (3) are on the left side of mount (4). To assemble otherwise will result in erratic throttle operation.

Loosen clamp and remove coolant line (5) to throttle body heater (6).

1. Throttle lever 2. Throttle cable 3. Adjustment nuts 4. Mount
5. Heater hose 6. Throttle body heater

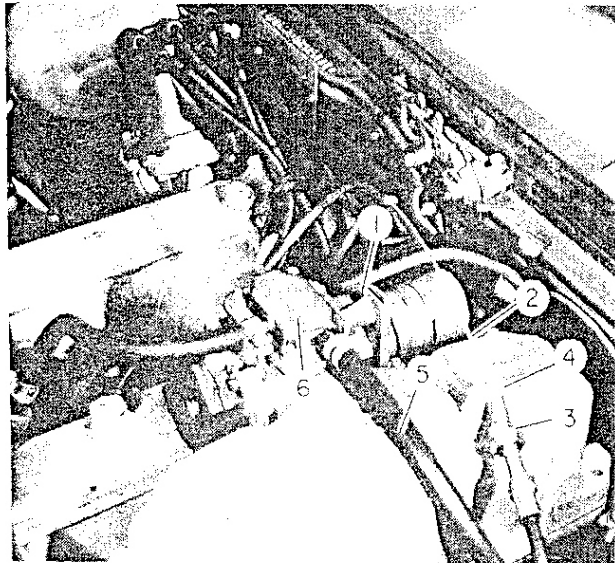

Before disconnecting fuel lines to engine, fuel pressure must first be released.

Remove fuel tank filler cap.

Remove vacuum hose (1) from fuel pressure regulator (2).

Using a hand vacuum pump (3) apply about 25 inches of vacuum to pressure regulator as shown. Fuel system pressure will then be released into fuel tank.

1. Vacuum hose 2. Fuel pressure regulator 3. Hand vacuum pump

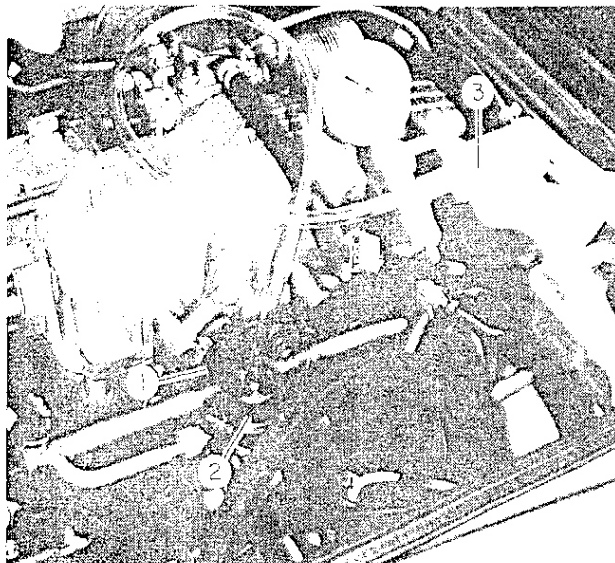

WARNING: Take all necessary precautions to prevent a fire when fuel lines are opened.

CAUTION: The fuel injection system is highly susceptible to contamination. Make sure area is clean whenever lines are opened up, and that dirt does not enter system.

Disconnect fuel return hose (1) from regulator (2). Disconnect fuel supply flex line fitting (3) from metal line (4) near left fender shield.

- 1. Fuel return hose
- 2. Fuel pressure regulator
- 3. Fuel supply line
- 4. Metal fuel supply line from pump

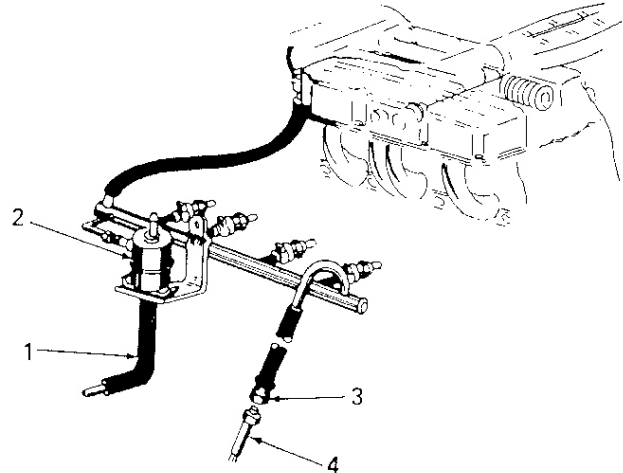

Mark to identify, then disconnect two water temperature electrical connectors (1) from top of cylinder head.

Loosen clamp and remove heater hose (2). Loosen clamp and remove crankcase breather hose (3).

If equipped with automatic transmission, remove bolt holding dipstick assembly to rear of right cam housing.

Disconnect white distributor lead wire from electronic control module on right fender shield. Disconnect black ground wire from module to rear of cylinder head.

Disconnect coil high voltage lead (4) from distributor.

- 1. Water temperature electrical connectors
- 2. Heater hose
- 3. Crankcase breather hose
- 4. Coil high voltage lead

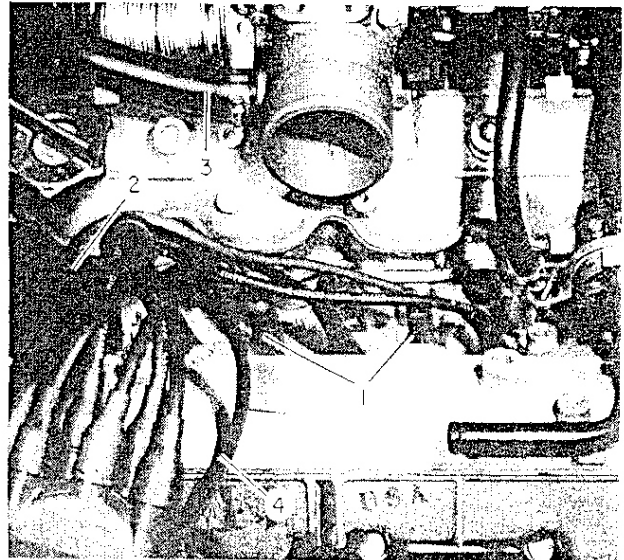

Loosen clamp and remove coolant hose (1) from controlled bypass thermostat (2). Loosen clamp on radiator hose (3) and remove from radiator.

Remove two bolts (4) to remove union (5) and attached hoses. Remove drive belts from crankshaft pulley.

Remove two nuts (6) and bolts to remove timing belt cover (7).

- 1. Coolant hose
- 2. Controlled bypass thermostat
- 3. Radiator hose
- 4. Bolt
- 5. Union
- 6. Nut
- 7. Timing belt cover

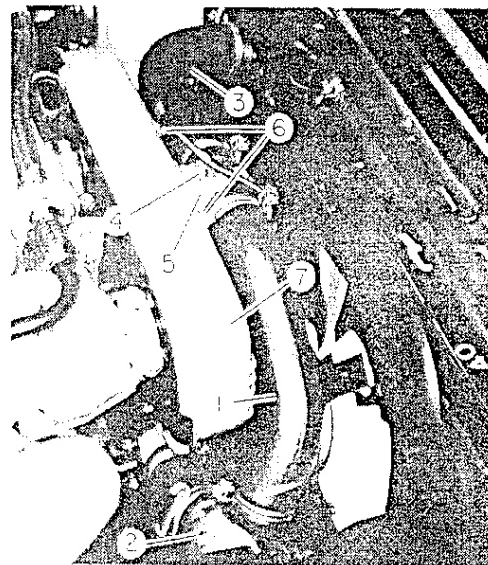

Manually turn engine until holes in camshaft sprockets align with timing pointers.

Block flywheel against turning.

Remove nut (4) holding crankshaft pulley (3). Use 38 mm socket. Remove pulley.

Remove four bolts (2, 5 and 8) and two nuts (1 and 6) holding lower sheet metal timing shield (7). Remove shield.

1. Nut 2. Bolt 3. Crankshaft pulley 4. Nut 5. Bolt 6. Nut
7. Timing belt shield 8. Bolt

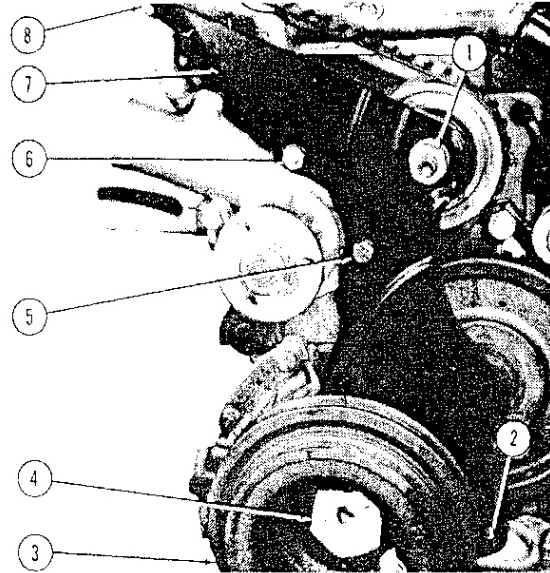

Loosen bolt (3) for tensioner bracket (4). Pry pulley in direction of arrow to release belt tension. Reinstall nut on pulley (1) and tighten it and bolt (3) to hold pulley in belt slackened position.

Remove timing belt (5). Mark belt as "not reusable".

Loosen but do not remove tensioner spring retaining bolt (2). Remove bolts to remove timing belt shields.

1. Tensioner pulley 2. Spring retaining bolt 3. Bolt 4. Tensioner bracket 5. Timing belt

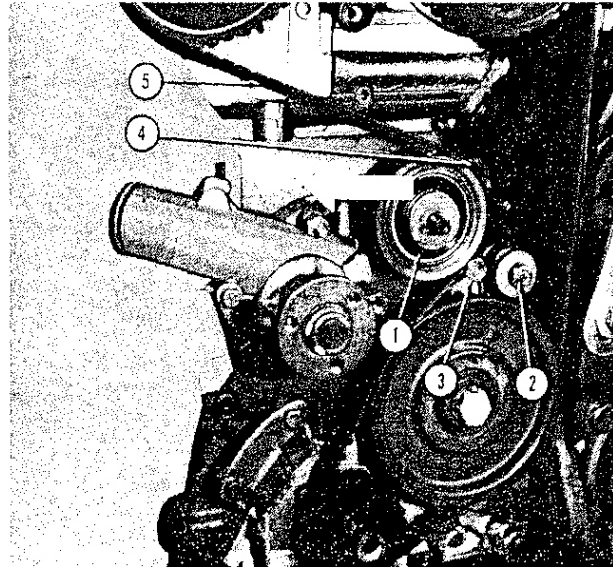

Remove nuts securing exhaust pipe to exhaust manifold. On turbo-charged engines remove nuts (1) holding shield (2) to exhaust manifold (3). Remove oil pressure line (4) to turbo unit (5). Remove three Allen head bolts (6) attaching turbo exhaust elbow to exhaust manifold.

1. Nut 2. Shield 3. Exhaust manifold 4. Oil pressure line
5. Turbo unit 6. Bolt

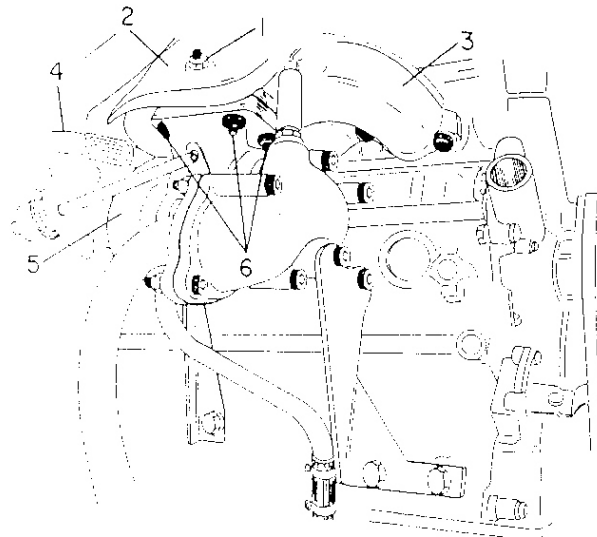

Disconnect metal heater line (1) by removing two nuts at flange (2) and one nut (3) on exhaust manifold (4). Remove ten cylinder head bolts and washers. Remove cylinder head and gasket.

1. Metal heater line 2. Flange 3. Nut 4. Exhaust manifold

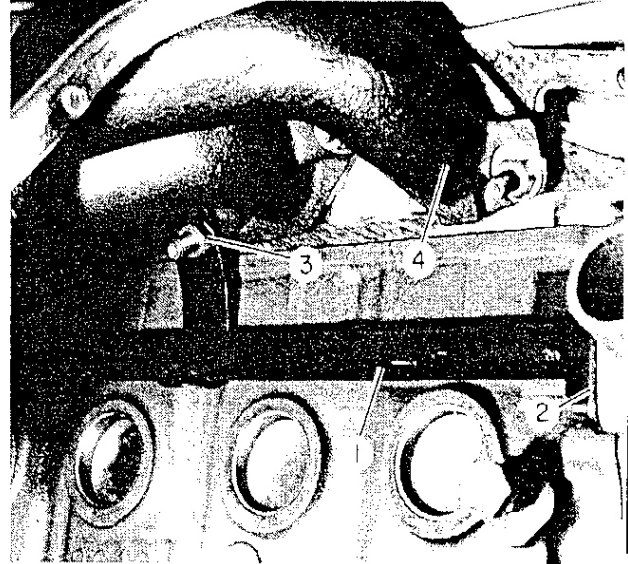

Install cylinder head in reverse order of removal.

Make sure word "ALTO" (top) on head gasket (1) is facing up, and that two guide dowels (2) are in place in cylinder block.

Install timing belt (refer to Camshaft Drive in this section).

Refill and bleed cooling system (refer to Radiator in this section).

Tighten head bolts in order shown. Torque in at least two stages, final torque will be 61 ft lbs (8.5 kgm).

1. Cylinder head gasket 2. Guide dowel

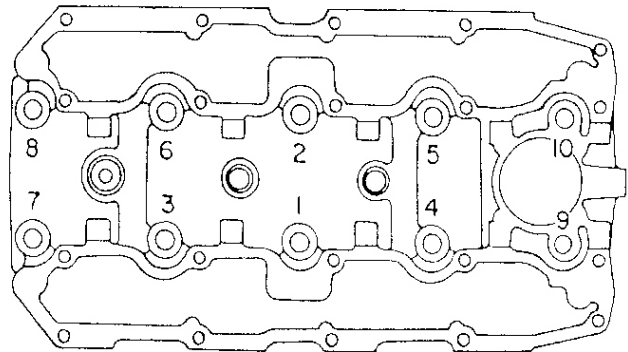
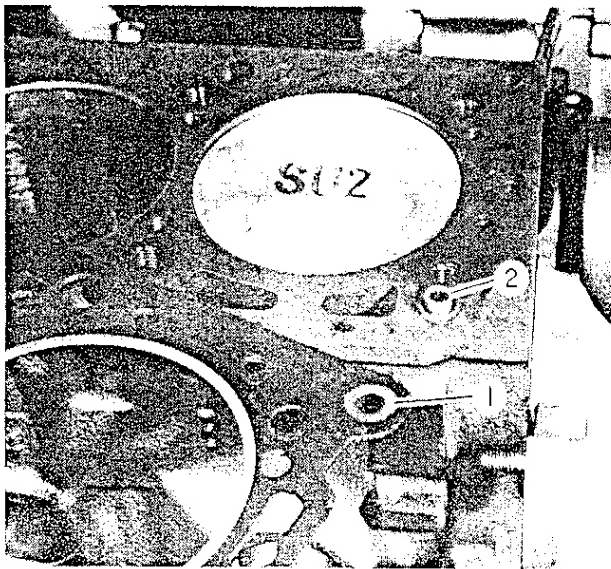

DISASSEMBLY AND ASSEMBLY (Carburetor)

Disconnect high voltage cables (1) from spark plugs (5).

Remove dirt from spark plug wells, then remove spark plugs.

Remove nut (4), washer and bracket (5), then remove distributor (3).

1. High voltage cables 2. Wire 3. Distributor 4. Nut 5. Bracket
6. Spark plug

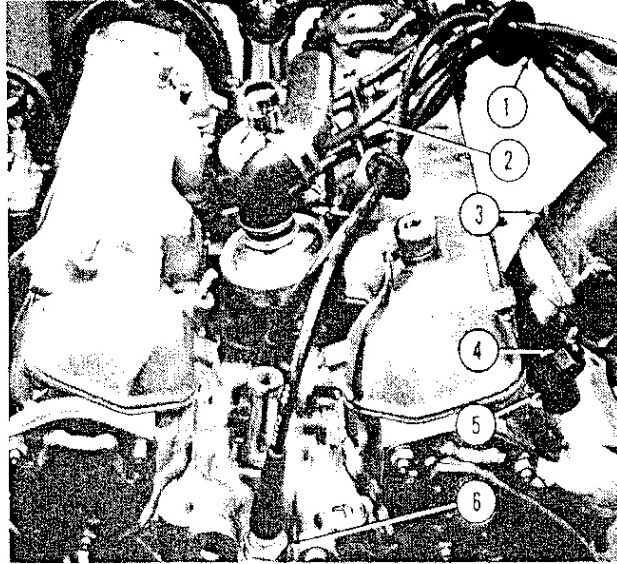

Remove water temperature sending unit (2).

On cars with air induction, remove reed valves (1).

On cars with air pump, remove air injection check valve.

Remove three nuts holding shield to exhaust manifold.

Remove five nuts and remove exhaust manifold (3).

Remove four bolts holding camshaft covers (4). Remove covers and gaskets.

1. Reed valves 2. Temperature sending unit 3. Exhaust manifold
4. Camshaft covers

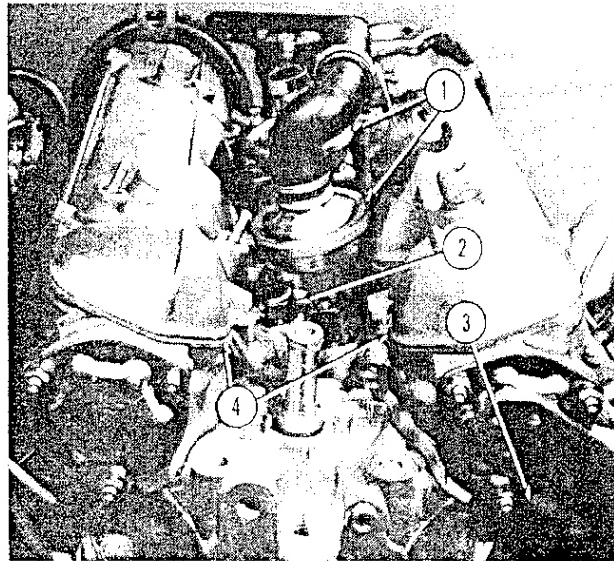

Disconnect hose (8) from EGR valve (7). Remove two bolts (6), then remove EGR valve.

Remove two vacuum hoses (9) from front of carburetor and two vacuum hoses (3) from side of carburetor.

Remove four nuts (1) and washers, remove the carburetor and spacer.

Remove two camhousing bolts holding vacuum tube brackets (2) to camhousing.

Remove four bolts (4), two nuts and washers. Remove intake manifold and gasket.

1. Nuts 2. Bracket 3. Vacuum hoses 4. Bolt 5. Intake manifold
6. Bolt 7. EGR valve 8. Hose 9. Vacuum hoses

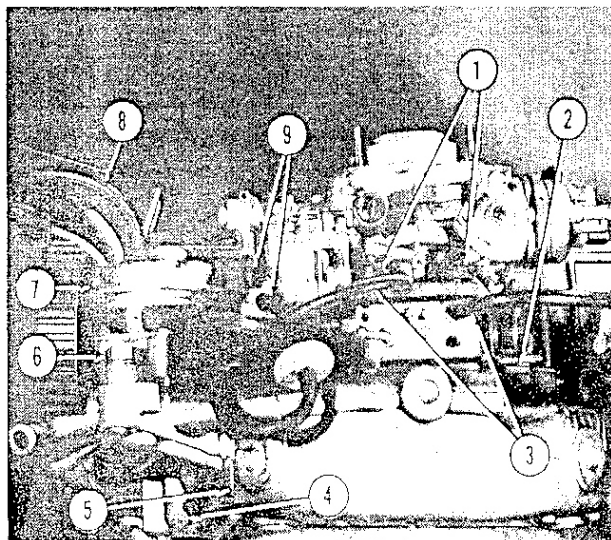

Remove two front camhousing bolts (1). Install tool A.60446 using bolts (1). Remove bolt (4) and washer. Remove camshaft pulley (3). Repeat for other side.

1. Bolt 2. Tool A.60446 3. Exhaust camshaft pulley 4. Bolt

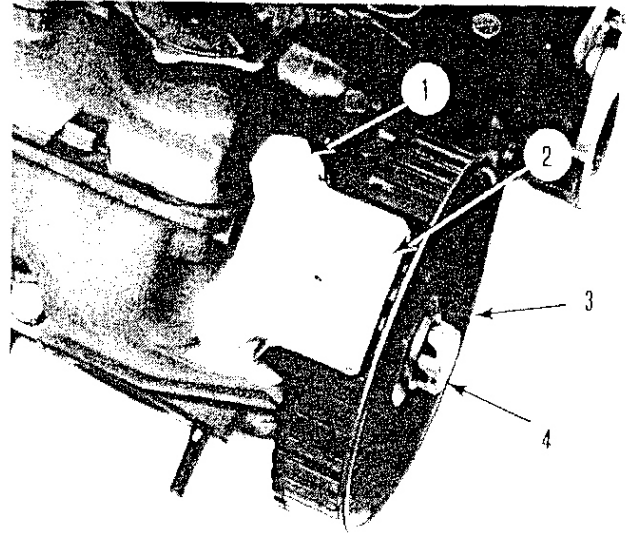

310

Remove three nuts (3) holding camshaft covers (4 and 5). Remove camshafts (2).

Remove bolts (6) holding cam housings (1 and 7). Remove housings and gaskets.

Remove two bolts (9) and washer holding water extension (8). Remove extension and gasket.

Assemble in reverse order.

1. Exhaust camhousing 2. Camshaft 3. Nuts 4. Cover 5. Cover
6. Camhousing bolts 7. Intake camhousing 8. Water extension
9. Bolts

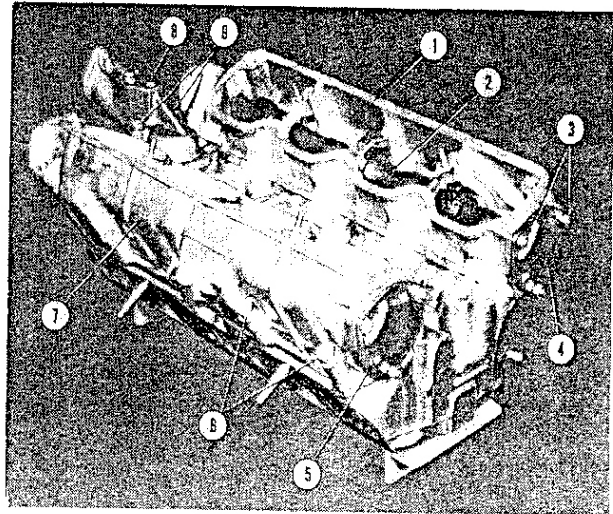

DISASSEMBLY AND ASSEMBLY (Fuel Injected and Turbo-Charged)

Disconnect high voltage cables (1) from spark plugs (2). Remove dirt from spark plug wells, then remove spark plugs. Remove nut (3), washer and bracket (4), then remove distributor (5). Remove water temperature sending units (6).

1. High voltage cables 2. Spark plug 3. Nut 4. Bracket
5. Distributor 6. Water temperature sending unit



Remove three nuts holding heat shield (1) to exhaust manifold (2). Remove five nuts and remove exhaust manifold.

- 1. Heat shield
- 2. Exhaust manifold

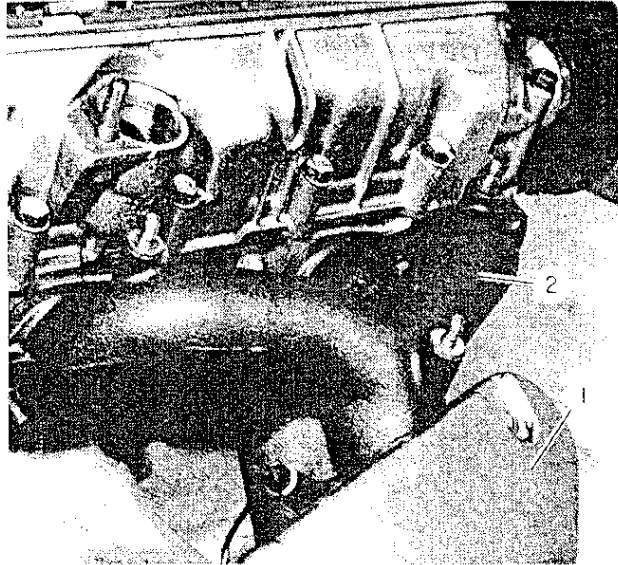

Remove four bolts (1) and two nuts (2) to remove intake manifold (3).

- 1. Bolt
- 2. Nut
- 3. Intake manifold

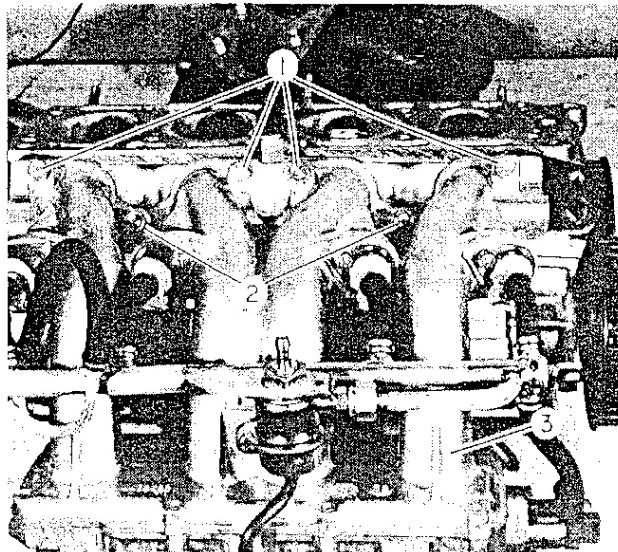

Remove two front camhousing bolts (1). Install tool A.60446 using bolts (1). Remove bolt (4) and washer. Remove camshaft pulley (3). Repeat for other side.

- 1. Bolt
- 2. Tool A.60446
- 3. Exhaust camshaft pulley
- 4. Bolt

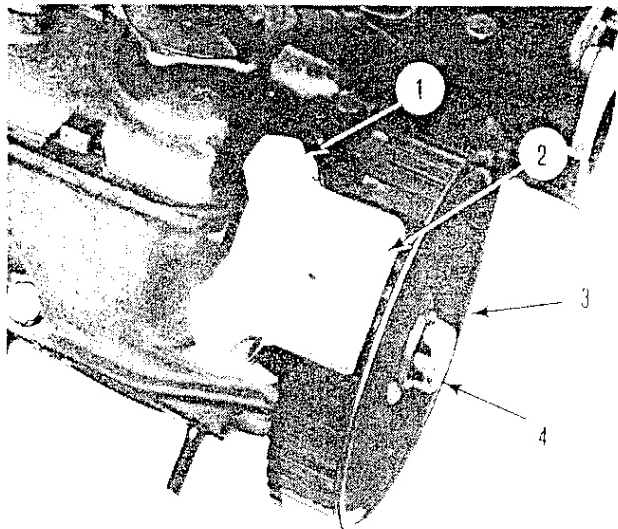

101

Remove three nuts (3) holding camshaft covers (4 and 5).
Remove camshafts (2).

Remove bolts (6) holding cam housings (1 and 7). Remove housings and gaskets.

Remove two bolts (9) and washer holding water extension (8).
Remove extension and gasket.

Assemble in reverse order.

1. Exhaust camhousing 2. Camshaft 3. Nuts 4. Cover 5. Cover
6. Camhousing bolts 7. Intake camhousing 8. Water extension
9. Bolts

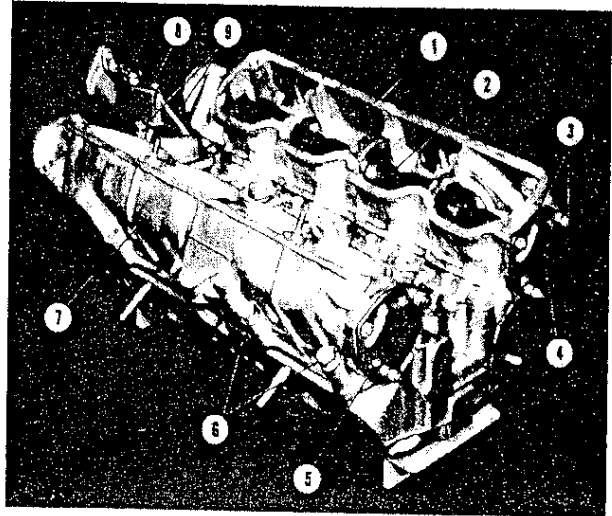

CHECKING CYLINDER HEAD GASKET SURFACE

Using a straight edge, check head for distortion. Lay straight edge across diagonals of gasket surface and lengthwise in the middle. The gap between head and straight edge must not exceed 0.002 inch. If gap exceeds this, reface cylinder head gasket surface.

Do not remove more material than necessary. Check depth of combustion chambers to make sure it has not been reduced below allowable limits.

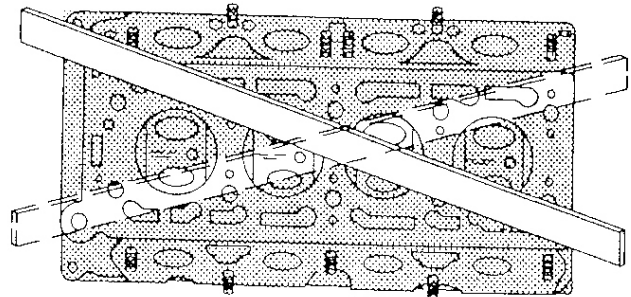

CHECKING DEPTH OF COMBUSTION CHAMBERS

Place gauge A.96229 (1) in center of combustion chamber. Check gap between gauge and surface of gasket. Use a feeler gauge (3).

Gap should not exceed 0.01 in. (0.25 mm).

1. Tool A.96229 2. Cylinder head 3. Feeler gauge

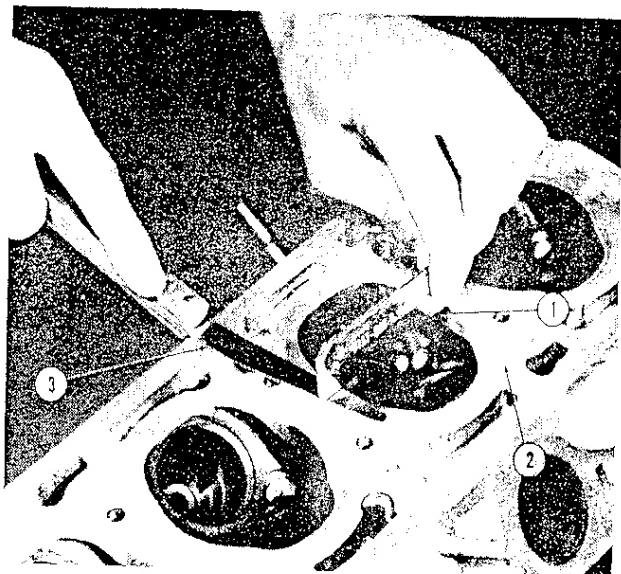

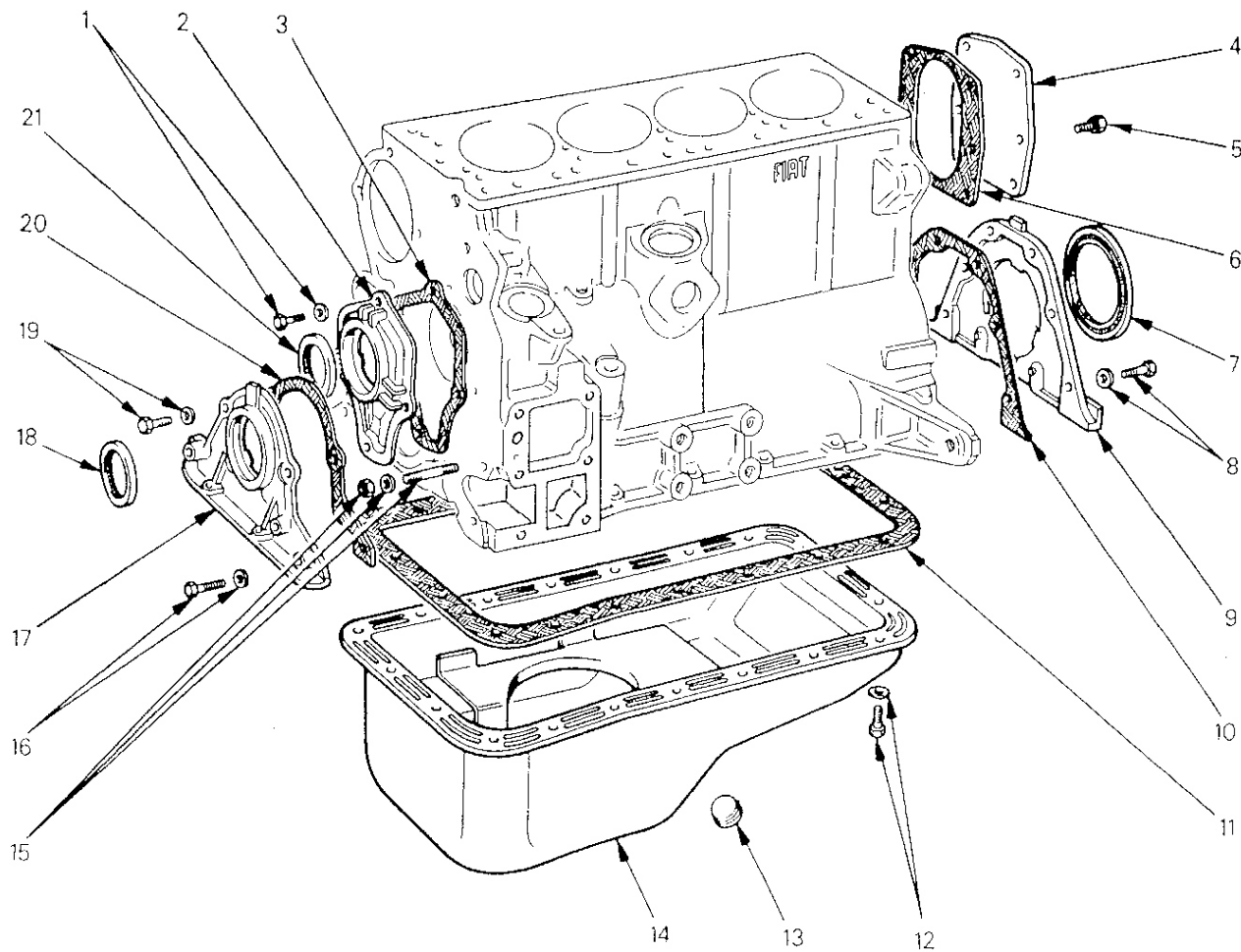

- 1. Bolt and lockwasher
- 2. Auxiliary shaft cover
- 3. Gasket
- 4. Cover
- 5. Bolt
- 6. Gasket
- 7. Oil seal
- 8. Bolt and lockwasher
- 9. Rear cover
- 10. Gasket
- 11. Gasket

- 12. Bolt and lockwasher
- 13. Drain plug
- 14. Oil sump
- 15. Stud, lockwasher, and nut
- 16. Bolt and lockwasher
- 17. Front cover
- 18. Oil seal
- 19. Bolt and lockwasher
- 20. Gasket
- 21. Oil seal

SEALS AND GASKETS

OIL SUMP AND CRANKCASE COVERS

REPLACEMENT

When overhauling engine, replace oil seals at crankshaft and auxiliary shaft.

Crankcase cover with oil seal

Arrows show indexes for positioning rear cover on crankshaft flange.

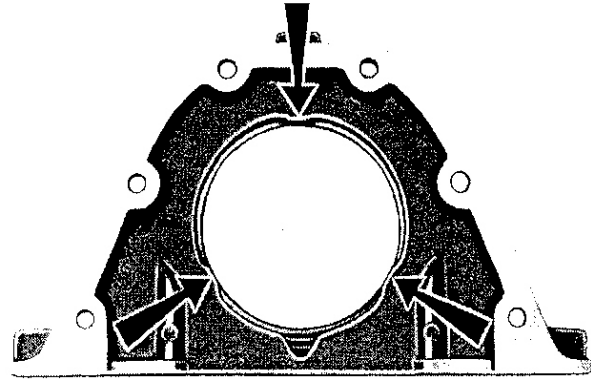

Engine front view

1. Crankshaft front cover
2. Crankshaft front oil seal
3. Auxiliary shaft cover
4. Auxiliary shaft oil seal

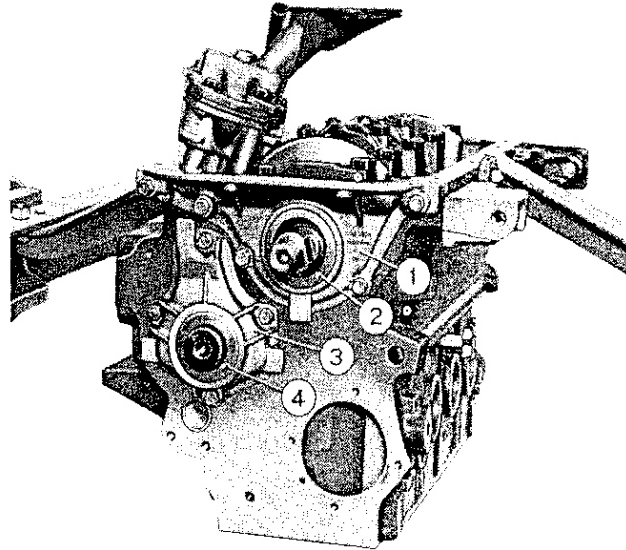

Auxiliary shaft and crankshaft covers with oil seals

Arrows show indexes for positioning covers on shafts.

