BRAKES - 33

PARTS CATALOG,
SERVICE MANUAL &
SERVICE TIME
SCHEDULE CODE

	PAGE
33	Specifications 33-1
	Torque Specifications 33-2
	Brake System 33-3
331.01	Brake Pedal Mechanism 33-5
331.02	Hydraulic Brake System 33-7
331.08	Power Brake Servo 33-15
331.17	Front Wheel Brakes 33-19
331.25	Rear Wheel Brakes 33-23
331.35	Hand Brakes 33-27
—	Service Tools 33-29

DATA AND SPECIFICATIONS

Type	hydraulically operated disc brakes on the four wheels, with dual brake circuit
Brake disc diameter	8.94" (227 mm)
Brake disc thickness:	
– nominal3917" to .3995" (9.95 to 10.15 mm)
– minimum allowable after refacing: front3680" (9.35 mm)
rear3719" (9.45 mm)
– minimum allowable from wear354" (9 mm)
Brake disc runout, maximum allowable (total dial indicator reading, at .08" – 2 mm apart from disc edge)006" (0.15 mm)
Brake lining clearance	self-adjusting
Distance between lining inner faces	not less than .41" (10.5 mm)
Lining thickness, minimum allowable0787" (2 mm) approx.
Master cylinder bore	3/4" (19.05 mm)
Brake calipers	floating, single cylinder type
Caliper cylinder bore: front	1-7/8" (48 mm)
rear	1-3/8" (34 mm)
Brake regulator	acting on rear wheels
– regulator ratio	0.46 to 1
Power brake	Vacuum type
– type	Master-Vac
– vacuum cylinder bore	6.2" (158.5 mm)
– distance between hydraulic piston control rod and master cylinder resting plate0408" to .0758" (1.035 to 1.925 mm)
Parking hand brake	acting mechanically on rear brake calipers

33

TORQUE SPECIFICATIONS

DESCRIPTION	THREAD (METRIC)	Kgm	TORQUE	
			N·m	FT. LB.
HYDRAULIC BRAKE SYSTEM				
Master cylinder nut	M 8	2.49	25	18
Brake regulator-to-body nut	M 8	1.52	15	11
Brake regulator-to-bracket bolt	M 8	1.9	20	14
Torsion bar link rod-to-axle case self-locking nut, type S .	M 6	.41	4.9	3
Caliper support bracket bolt		5	49	36
PEDALS				
Brake and clutch pedal nut	M 12 x 1.25	1.9	20	14
Pedal support-to-dashboard nut	M 8	1.52	15	11
Pedal support-to-crossmember nut	M 8	2.49	25	18
ELECTRICAL				
Back-up light switch (5 A)	M 14 x 1.5	4.42	43	32
POWER BRAKE				
Power brake-to-support nut	M 8	2.49	25	18

33

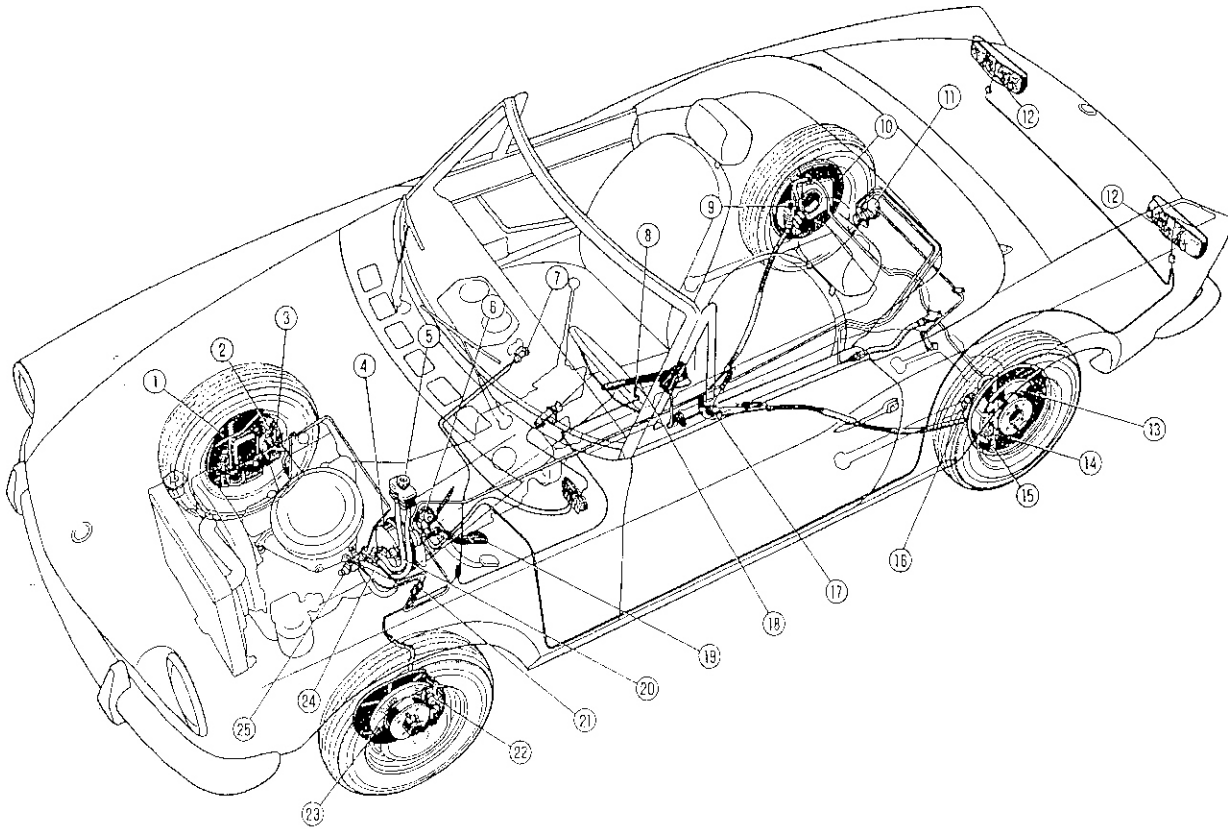

1. Front brake disc shield
2. Front brake bleeder connection
3. Front brake calipers
4. Vacuum servo
5. Dual brake fluid reservoir with level switch
6. Stop lights switch
7. Brake circuit effectiveness and hand brake ON indicator
8. Jam switch for hand-brake ON signal and efficiency indicator
9. Rear brake bleeder connection
10. Rear brake disc shield
11. Braking action compensator
12. Stop lights
13. Rear brake disc
14. Caliper carrier plate
15. Rear disc brake caliper
16. Mechanical parking hand brake
17. Hand brake cable stretcher
18. Hand brake control lever
19. Service brake pedal
20. Front brake circuit
21. Pressure switch for indicator 7
22. Friction pad carrier plate
23. Front brake disc
24. Rear brake circuit
25. Master cylinder with two co-axial pistons

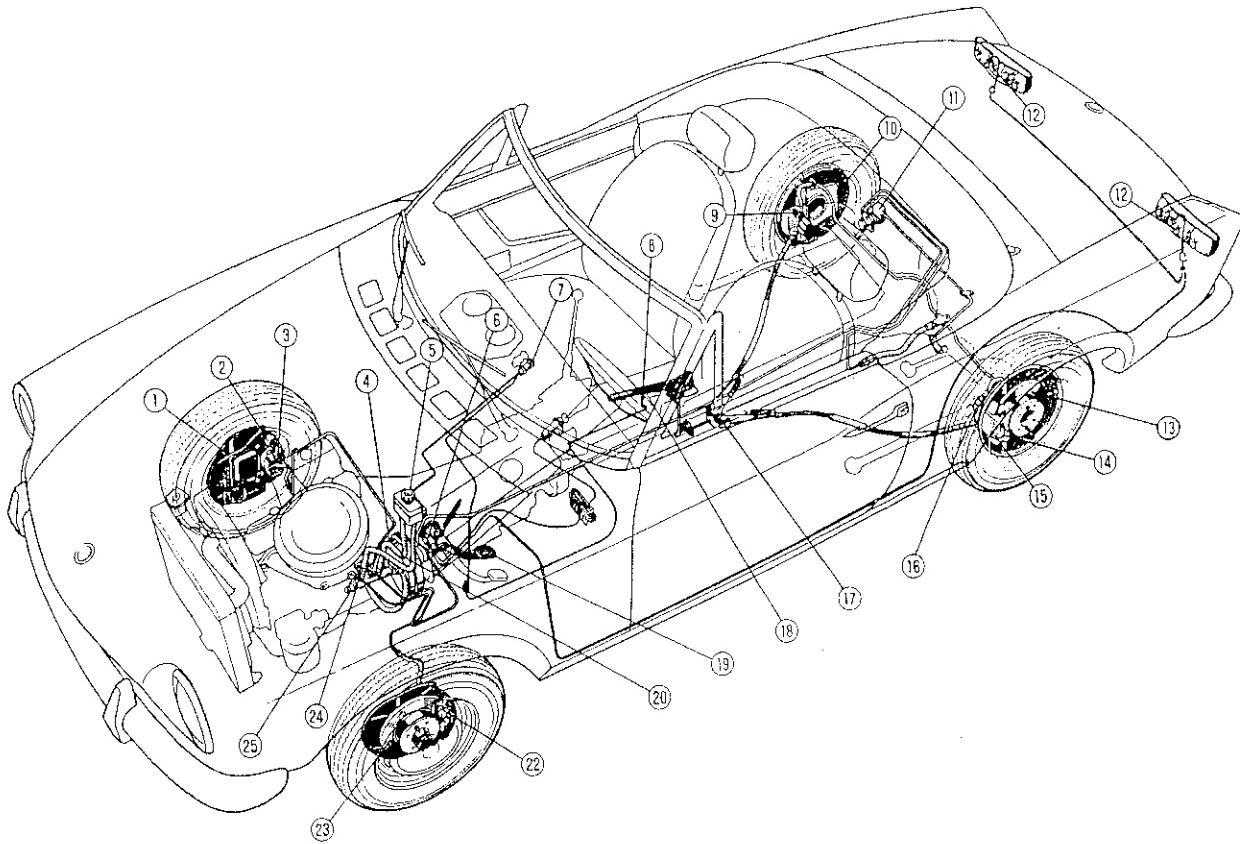

1. Front brake disc shield
2. Front brake bleeder connection
3. Front brake calipers
4. Vacuum servo
5. Dual brake fluid reservoir with level switch
6. Stop lights switch
7. Brake circuit effectiveness and hand brake ON indicator
8. Jam switch for hand-brake ON signal and efficiency indicator
9. Rear brake bleeder connection
10. Rear brake disc shield
11. Braking action compensator
12. Stop lights
13. Rear brake disc
14. Caliper carrier plate
15. Rear disc brake caliper
16. Mechanical parking hand brake
17. Hand brake cable stretcher
18. Hand brake control lever
19. Service brake pedal
20. Front brake circuit
22. Friction pad carrier plate
23. Front brake disc
24. Rear brake circuit
25. Master cylinder with two co-axial pistons

Brake Pedal Mechanism

331.01

Page 33-5/6

BRAKE PEDAL

REMOVAL AND INSTALLATION (Manual Transmission)

Remove brake and clutch pedal return springs (1).

Remove retainer clip (2) and pin (3) to release servo push rod (4) from brake pedal (5).

Using 5/8 in. wrench, remove pivot bolt (6) and nut (7). Remove brake and clutch pedals along with spacers (8) and bushings (9).

Installation is reverse of removal. Lubricate all bearing surfaces with white grease.

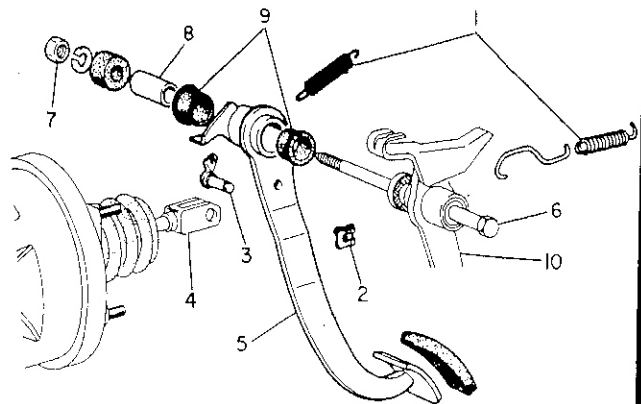

1. Return spring 2. Retainer clip 3. Pin 4. Servo push rod
5. Brake pedal 6. Pivot bolt 7. Nut 8. Spacer 9. Bushing
10. Clutch pedal

BRAKE PEDAL

REMOVAL AND INSTALLATION (Automatic Transmission)

Remove brake pedal (1) return spring (2).

Remove retainer clip (3) and pin (4) to release servo push rod (5) from brake pedal.

Using 5/8 in. wrench, remove pivot bolt (6) and nut (7). Remove brake pedal along with spacers (8) and bushings (9).

Installation is reverse of removal. Lubricate all bearing surfaces with white grease.

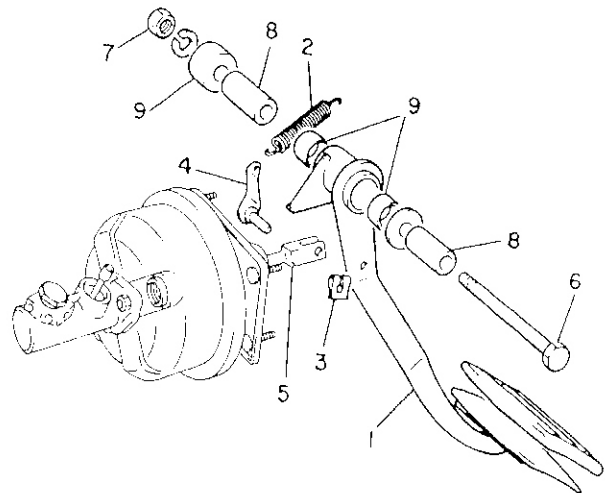

1. Brake pedal 2. Return spring 3. Retainer clip 4. Pin 5. Servo push rod
6. Pivot bolt 7. Nut 8. Spacer 9. Bushing

RESERVOIR AND MASTER CYLINDER

REMOVAL AND INSTALLATION

While holding brake fluid level switch (1), unscrew cover (2) from reservoir (3). Drain or siphon reservoir fluid.

CAUTION: Provide container to catch brake fluid. Do not allow fluid to contact paint surfaces.

Using gentle side-to-side rocking motion, pull reservoir lines (4) from master cylinder (5). Remove two bolts (6) holding reservoir support bracket (11) to firewall and remove reservoir assembly. Disconnect three brake lines (7, 8 & 9) from master cylinder. Cap lines to prevent dirt entry. Remove two nuts (12) and lockwashers, then pull master cylinder away from power brake servo (10). Install in reverse order of removal making sure all parts and fittings are clean.

1. Fluid level switch 2. Reservoir cover 3. Reservoir 4. Reservoir lines 5. Master cylinder 6. Bolt 7. Brake line, rear 8. Brake line, left front 9. Brake line, right front 10. Power brake servo 11. Bracket 12. Nut

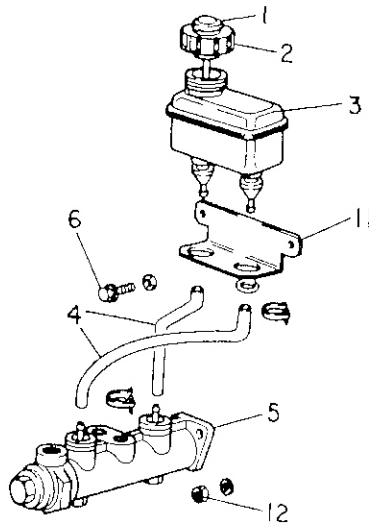
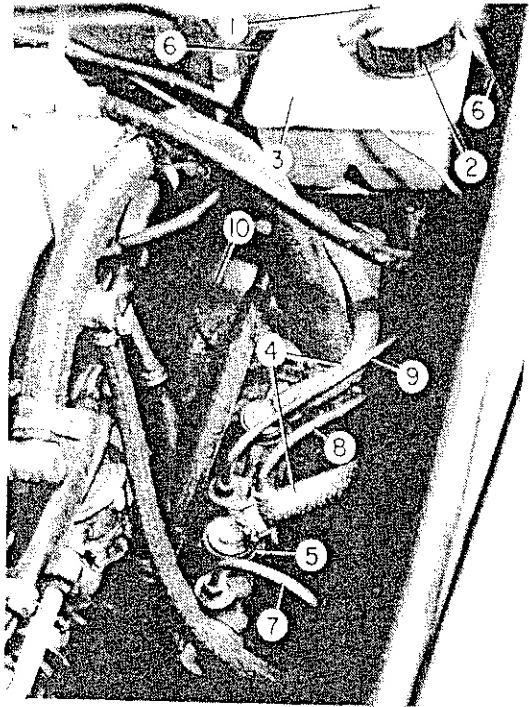

MASTER CYLINDER OVERHAUL

Remove two connectors (1) and dust cover (2).

Remove two stop bolts (15) and seals (16).

Remove remaining internal parts (items 3 through 14) from body (17).

Carefully inspect cylinder bore and piston surfaces. They should have a mirror-like finish without any kind of roughness. The cylinder bore can be honed to prevent leaks or excessive wear of seals and pistons. Do not increase size of bore. Replace seals and dust covers. Clean all parts with denatured alcohol and lubricate with brake fluid. Reassemble in reverse order of disassembly.

33

1. Connector
2. Seal
3. Rear piston
4. Spacer
5. Seal
6. Spring and cup
7. Spring and cup
8. Flat washer
9. Seal
10. Front piston
11. Spring and cup
12. Seal
13. Spacer
14. Spring and cup
15. Stop bolt
16. Seal
17. Cylinder body

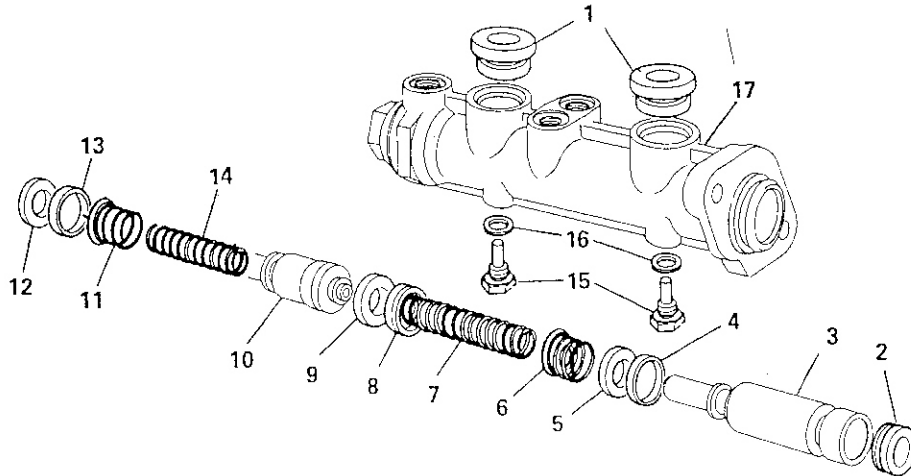

FRONT CALIPER OVERHAUL

Remove caliper (Refer to FRONT WHEEL BRAKES).

To disassemble caliper, remove dust seal (4). Then apply compressed air to brake fluid hose connection (2) to remove piston (5).

WARNING: Apply air pressure gradually or piston will eject with high force.

Remove seal from caliper bore using care not to damage bore surface.

Inspect caliper bore (7) for corrosion, scoring, or pitting. Replace entire caliper if damaged.

Replace piston (8), seal (6) and dust cover (4).

Clean all parts with denatured alcohol, and lubricate with brake fluid. Assemble in reverse order of disassembly using care not to damage surface of caliper bore or piston.

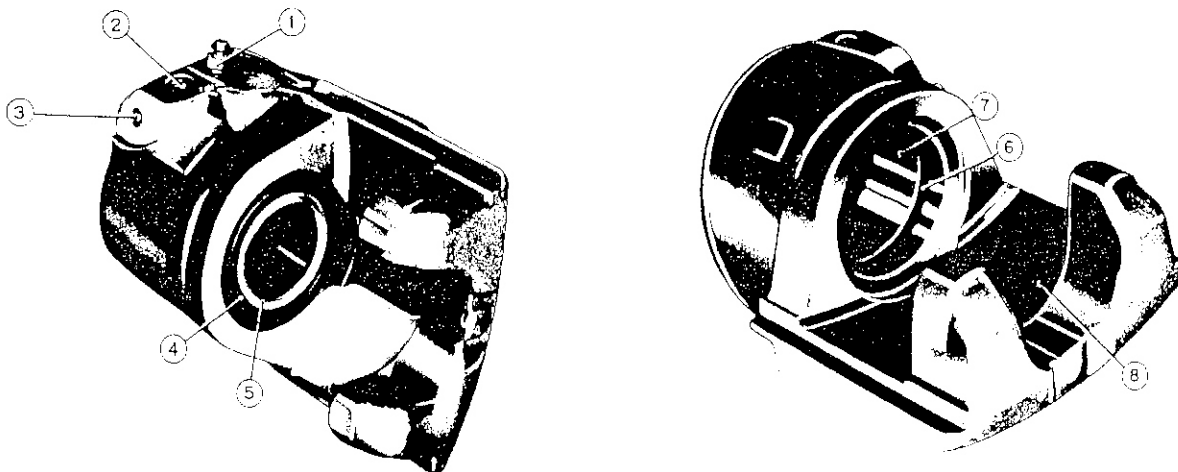

1. Bleed screw
2. Brake fluid hose connection
3. Locking plate bolt hole
4. Dust seal
5. Piston
6. Piston seal
7. Piston bore
8. Caliper body

REAR CALIPER OVERHAUL

Remove dust seal (15). Remove piston (13) by unscrewing it from brake plunger (6) using a screwdriver in slot formed in piston head. Remove piston seal (14) from caliper bore using care not to damage bore surface. Remove hand brake lever dust cover (1). Withdraw snap ring (3) and bushing (2) from cam lever (5).

Remove cam lever, hand brake plunger, plunger seal (9), disc springs (7) and spring thrust washer (8).

Inspect caliper bore for corrosion, scoring or pitting. Replace entire caliper if damaged.

Replace piston (13), seal (14), and dust seal (15). Replace any worn or damaged components from hand brake assembly.

Assemble in reverse order of disassembly using care not to damage surface of caliper bore or piston. Screw piston in all the way with mark "A" opposite bleed screw (11).

CAUTION: Reference mark "A" must be on side of bleed screw or system cannot be bled properly and brake action will be irregular.

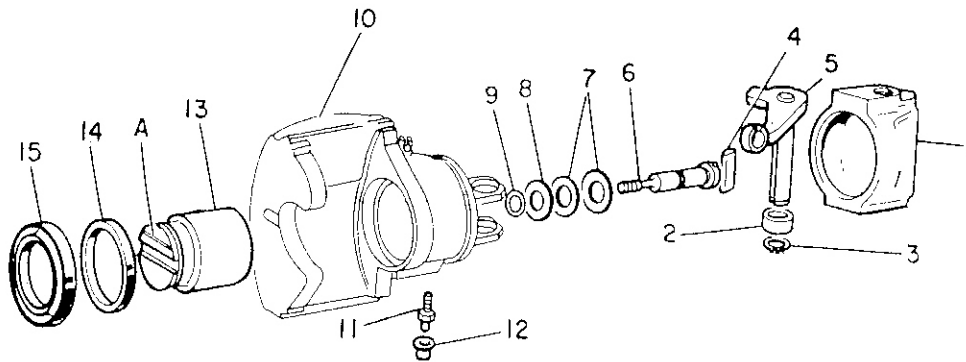

1. Dust cover
2. Bushing
3. Snap ring
4. Pawl
5. Hand brake cam lever

6. Plunger
7. Disc springs
8. Thrust washer
9. Plunger seal
10. Caliper body

11. Bleed screw
12. Protective cap
13. Piston
14. Piston seal
15. Dust seal

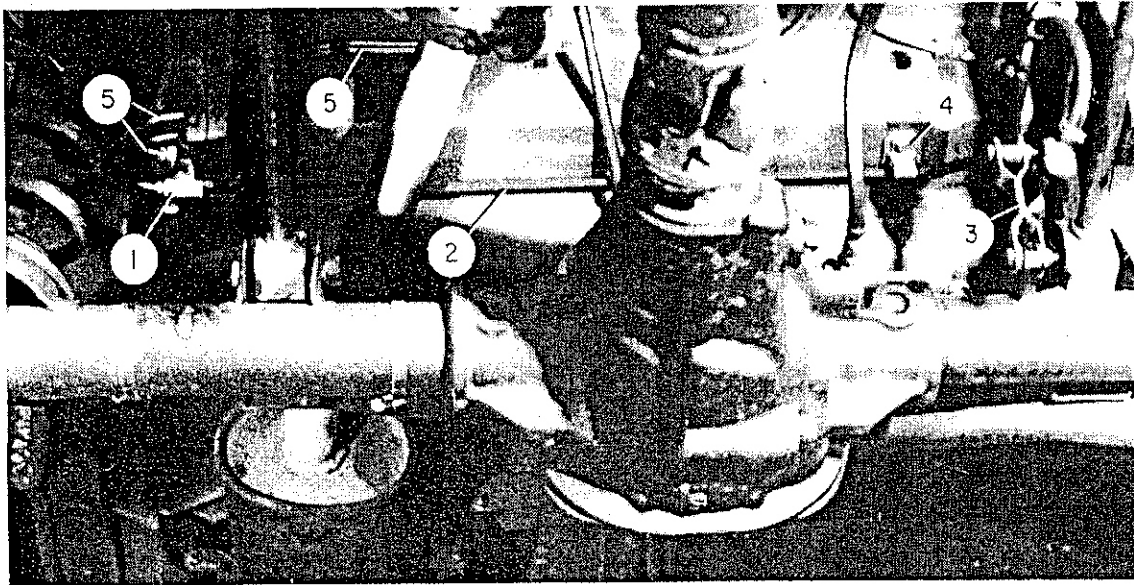

COMPENSATOR CONTROL SYSTEM

1. Compensator valve 2. Torsion bar 3. Torsion bar link 4. Mounting bracket 5. Fluid lines

The function of rear brake compensator system is to regulate brake fluid pressure to rear calipers. The amount of pressure delivered to rear calipers is directly proportional to the load on rear wheels. As load increases or decreases, the torsion bar transmits load changes to the compensator valve which then regulates amount of fluid pressure to rear calipers. With increased load more pressure is delivered, a decreased load lessens pressure to calipers.

COMPENSATOR

REMOVAL

Disconnect two brake fluid lines (1 & 2) from compensator valve (3). Cap to prevent dirt entry. Remove protection boot from compensator by unclipping plastic clamp (4). Move boot to gain access to torsion bar pivot bolt. Loosen bolt. Remove right rear road wheel. Remove three nuts (5) holding regulator mounting bracket (6) to frame. Remove bracket and regulator assembly from torsion bar. Separate regulator from bracket by removing two bolts (8).

1. Fluid line to rear brakes 2. Fluid line from master cylinder 3. Compensator valve 4. Plastic clamp 5. Nut 6. Mounting bracket
7. Rubber bumper 8. Bolt

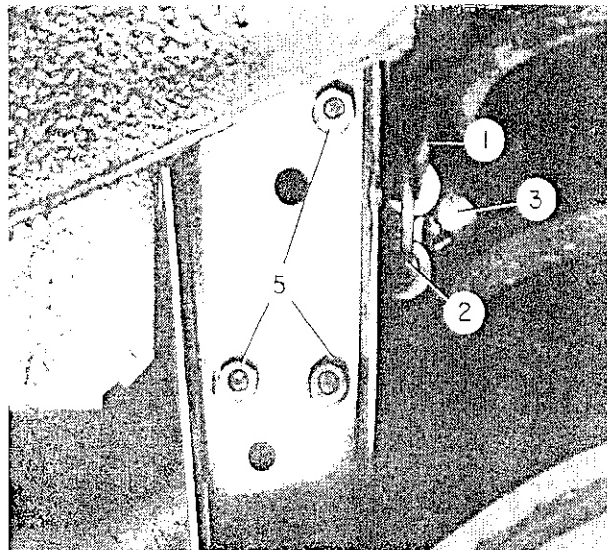
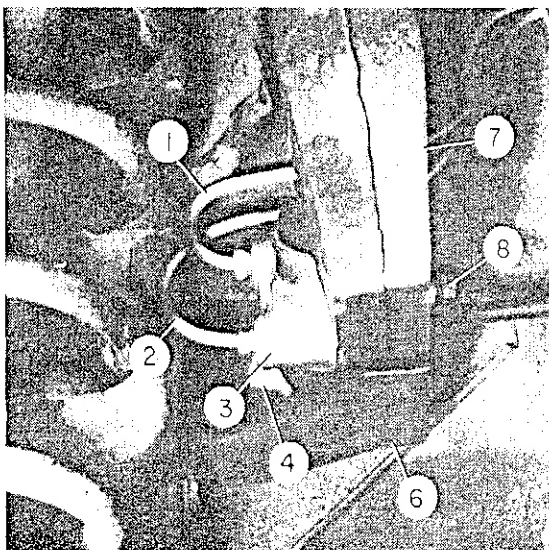

Hydraulic Brake System

331.02

Page 33-11

To remove torsion bar (1), remove two bolts (2) and lockwashers holding torsion bar support bracket (3). Then remove bolt (4) and nut (5) from torsion bar link (6).

1. Torsion bar 2. Bolt 3. Support bracket 4. Bolt 5. Nut
6. Torsion bar link

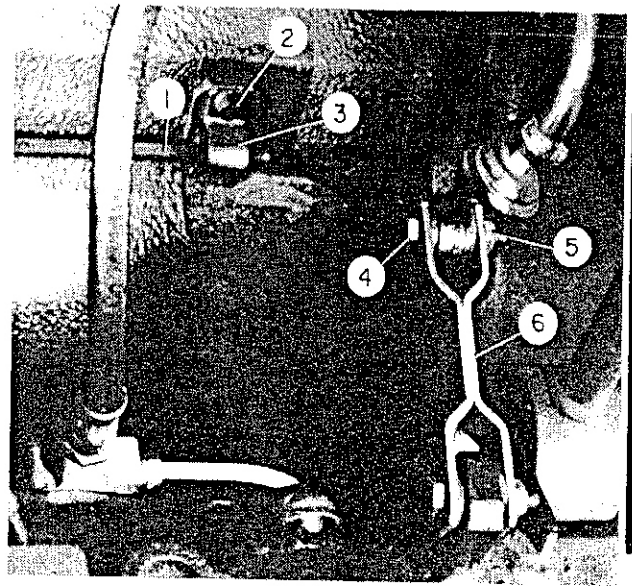

INSPECTION

Inspect compensator valve for leaks or jammed piston. Overhaul or replace if damaged (Refer to COMPENSATOR VALVE OVERHAUL).

Check that torsion bar pivot is not worn. Replace if worn.

Check that all bushings are not worn or deteriorated. Replace if damaged.

Check rubber boot for breaks or cracks that would permit moisture entry. Replace, if damaged.

INSTALLATION

Coat bushings with silicone grease, and pivot with chassis grease.

Assemble all parts to the vehicle except do not fully tighten compensator valve bolts and do not attach torsion bar to connecting link.

Bleed system (Refer to BLEEDING HYDRAULIC SYSTEM).

Perform adjustment (Refer to COMPENSATOR CONTROL ADJUSTMENT).

Clean all parts in denatured alcohol. Lubricate with brake fluid. Reassemble in reverse order of disassembly.

COMPENSATOR VALVE OVERHAUL

Using tool A.56124 or similar type wrench, remove plug (1). Remove remaining parts (items 2 and 9) from body (10).

Inspect piston (4) and body (10) for wear, pitting, corrosion, scratches, or cracks.

Replace entire compensator valve if piston or body is damaged.

Replace seals (5 and 9) and cups (6 and 8). Check remaining parts for damage. Replace if damaged.

Clean all parts in denatured alcohol. Lubricate with brake fluid. Reassemble in reverse order of disassembly.

1. Plug
2. Gasket
3. Bushing
4. Piston
5. Seal
6. Cup
7. Spring
8. Cup
9. Seal
10. Body

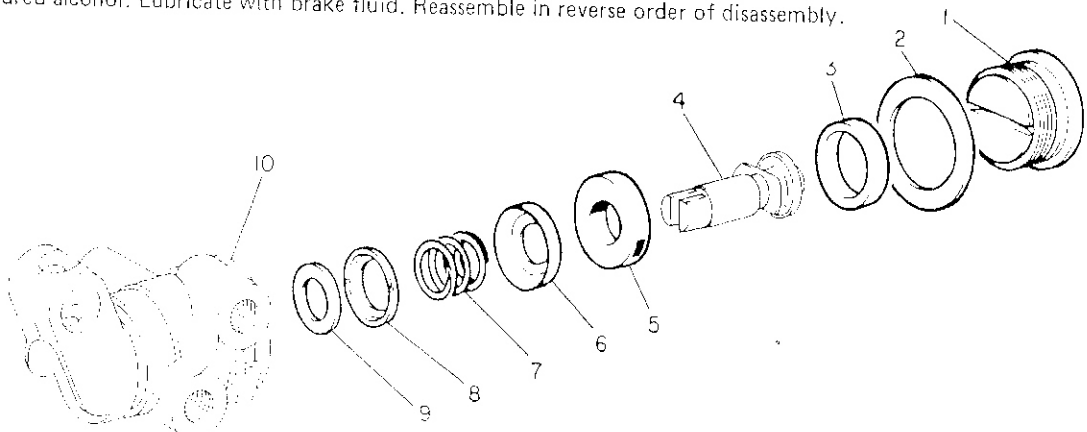

COMPENSATOR CONTROL

ADJUSTMENT

Raise vehicle on lift.

NOTE: Adjustment can be accomplished on either drive-on or frame type lifts.

Loosen bolts (2) securing compensator (3) to support bracket (4). Unclip plastic clamp and slide dust boot (5) from compensator. Remove bolt and nut (6) to disconnect torsion bar (7) from connecting link (8). Bring end of torsion bar pivot point to distance "X" of $5.787 \pm .196$ in. (147 ± 5 mm) as measured with a ruler held "straight up". Dimension "X" is measured from center of torsion bar pivot point to underside of floor pan (1).

With torsion bar held in this position, rotate compensator until piston (9) is just touching torsion bar (7a). Torque bolts (2) to 18 ft lbs (2.5 kgm) to secure compensator in this position.

Connect torsion bar to connecting link.

Slide dust boot on compensator and install plastic clamp.

1. Floor pan
2. Bolt
3. Compensator valve
4. Mounting bracket
5. Dust boot
6. Nut
7. & 7a. Torsion bar
8. Connecting link
9. Piston

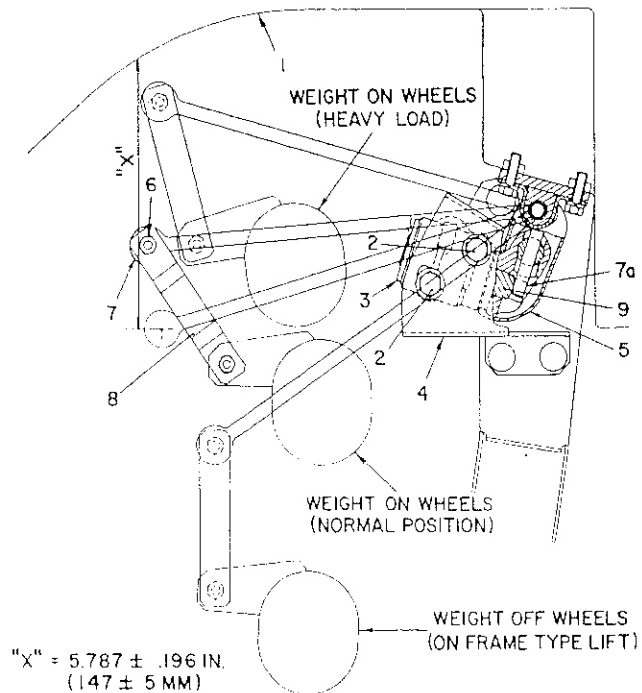

BRAKE LINES

REMOVAL AND INSTALLATION

Brake lines normally last the life of the vehicle. However, if damaged, brake lines may be repaired by splicing in a new section of line, or must be replaced. When replaced, make sure lines are secured to prevent chafing from vibration.

After installing, bleed system (Refer to HYDRAULIC SYSTEM BLEEDING).

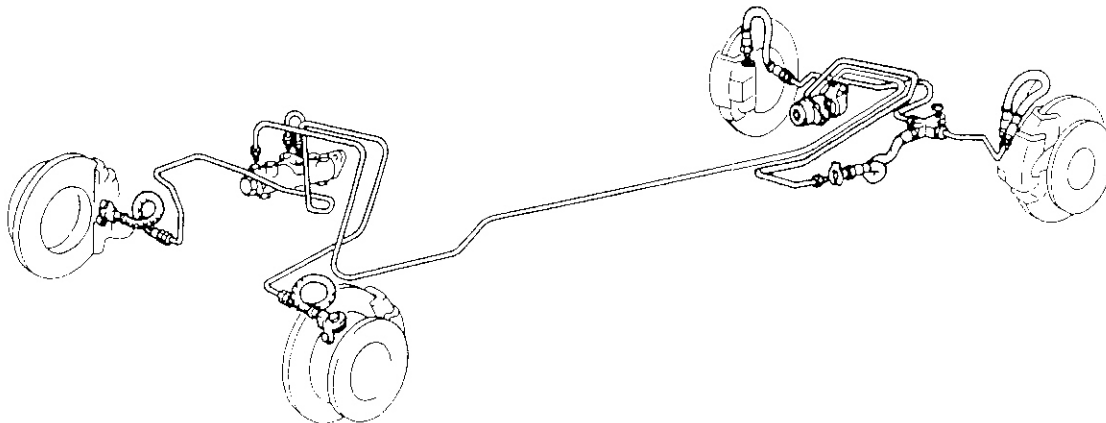

BRAKE HOSES

REMOVAL AND INSTALLATION

Remove connector (5) and bolt (1) to remove brake hose (2).
Check that hose is not frayed, worn or brittle. Replace if damaged.

When installing, use new gaskets (3).

Bleed system (Refer to HYDRAULIC SYSTEM BLEEDING).

1. Bolt 2. Hose 3. Gasket 4. Bracket 5. Connector

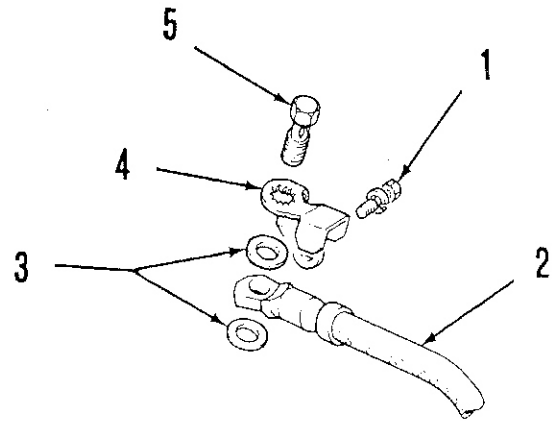

HYDRAULIC SYSTEM

BLEEDING

When the front or rear hydraulic system is opened for any reason, it must be bled to remove all entrapped air. The front and rear systems are independent and need not be bled together. After all repairs are made, proceed as follows:

NOTE: Should the brake system have been completely drained, it is advisable to carry out the following operation before bleeding: Loosen all wheel bleeder screws and pump brake pedal, as fluid begins to escape tighten bleeder screws. Keep fluid reservoir filled with DOT 3 brake fluid.

Clean all dirt and foreign material from bleeder screws and remove protective cap.

Attach bleeder hose over bleeder fitting in brake caliper. Submerge other end of bleeder hose into a clean jar half filled with brake fluid.

Loosen bleeder screw one or two turns and press brake pedal down, allowing it to return slowly. Do this several times until no more air bubbles escape from rubber hose.

Keep brake pedal depressed, remove bleeder hose and tighten bleeder screw. Refit protection cap.

Repeat above on other wheels, making certain that fluid level in reservoir is maintained.

After bleeding, top up reservoir to prescribed maximum level.

1. Bleed screw 2. Bleed hose 3. Front brake assembly 4. Rear brake assembly

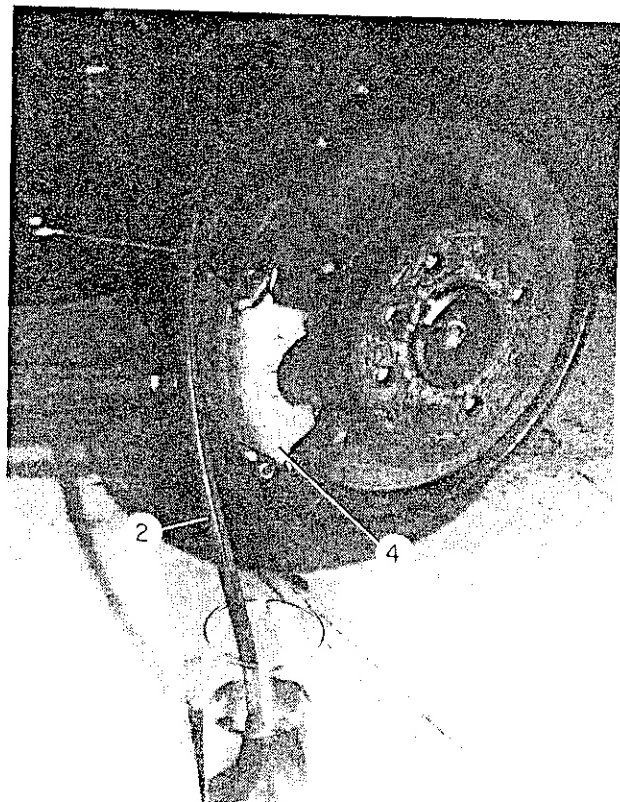
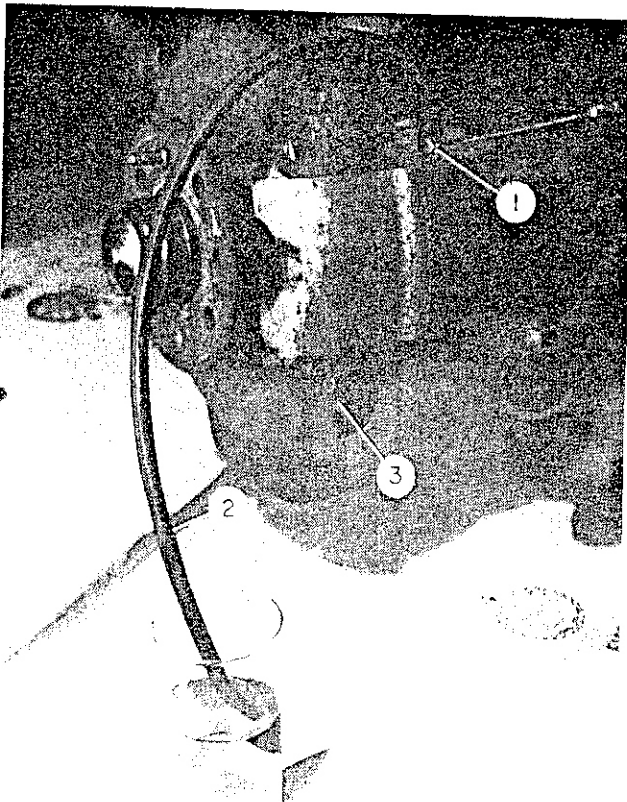

**FOLD OUT
PAGE GOES
HERE**

**REFER TO
FOLDOUT.PDF**

POWER BRAKE SERVO

REMOVAL AND INSTALLATION

Remove reservoir and master cylinder (Refer to RESERVOIR AND MASTER CYLINDER REMOVAL AND INSTALLATION).

Loosen clamp (4). Disconnect vacuum hose (5) from brake servo (3).

From inside vehicle, remove return spring (8), clip (9) and pin (7) from servo push rod (2). Remove four nuts (1) and lockwashers to remove servo from mounting plate (6).

Install in reverse order of removal.

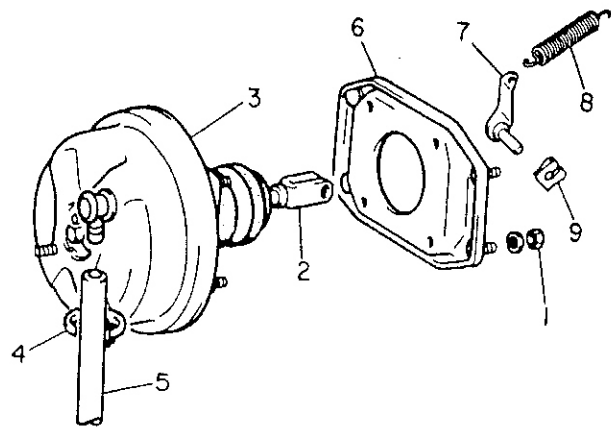

1. Nut 2. Brake servo push rod 3. Brake servo 4. Clamp
5. Vacuum hose 6. Mounting plate 7. Pin 8. Spring 9. Clip

OVERHAUL

Remove check valve (9) by carefully pulling from bushing (10). Using wood blocks positioned on the six mounting studs, place brake servo in a vise.

Carefully squeeze front cover (6) and rear chamber (18) until rear chamber can be twisted to clear the lock tabs on front cover.

WARNING: Use care when releasing vise. Servo is spring loaded.

Carefully open vise until spring (5) pressure is released. Remove from vise and separate parts.

Remove rubber boot (19). Remove metal cup (13) and key (2) to remove plunger and valve (11). Separate remaining parts. Do not upset adjustment on vacuum piston rod (4).

Replace the following kit supplied parts: bushing plate (3), front seal (7), filter (12), cup (13), diaphragm (14), cup (15), seal (16), rear seal (17) and rubber boot (19).

Inspect remaining parts for damage and wear. Replace as required. Lubricate shafts of vacuum piston rod (4), plunger and valve (11) with white grease. Reassemble in reverse order of disassembly.

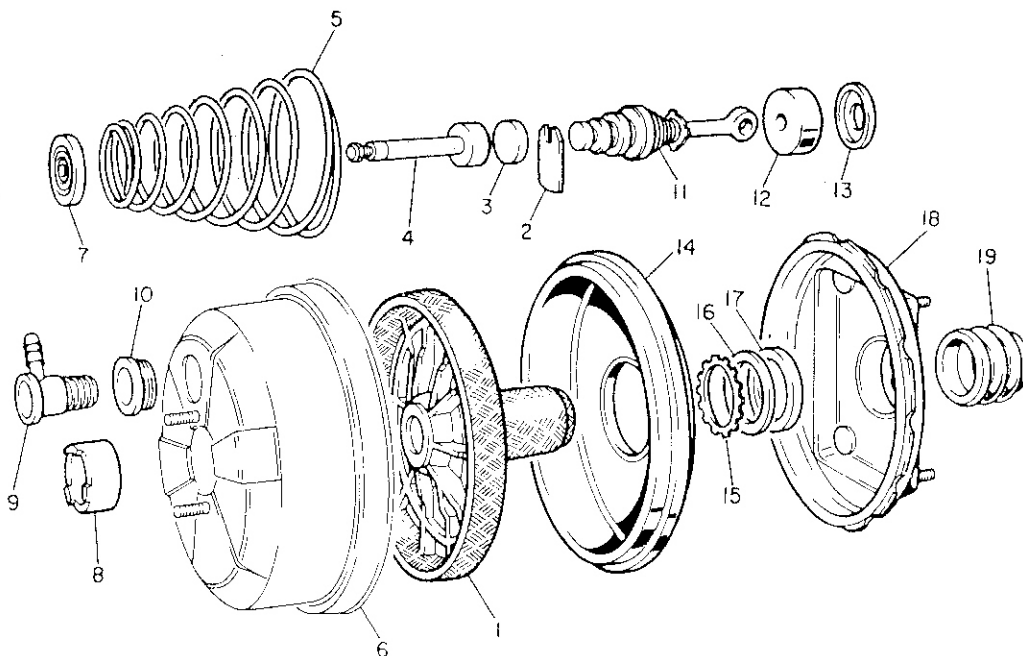

- | | | | |
|----------------------|------------------|-----------------------|------------------|
| 1. Vacuum piston | 6. Front cover | 11. Plunger and valve | 16. Seal |
| 2. Key | 7. Front seal | 12. Filter | 17. Rear seal |
| 3. Backing plate | 8. Guide bushing | 13. Cup | 18. Rear chamber |
| 4. Vacuum piston rod | 9. Check valve | 14. Diaphragm | 19. Rubber boot |
| 5. Spring | 10. Bushing | 15. Cup | |

After completing reassembly, adjust tip (2) of vacuum piston rod (1) to extend past front cover (3) by 0.0408 to 0.0758 in. (1.035 to 1.925 mm).

- 1. Vacuum piston rod
- 2. Tip
- 3. Front cover

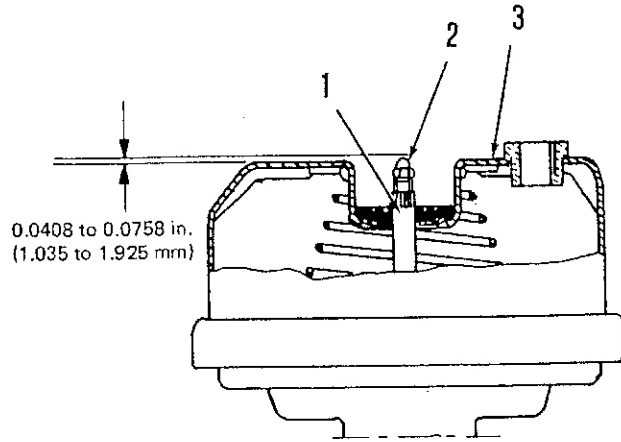

3
3

CALIPER AND PADS

REMOVAL AND INSTALLATION

Remove wheels.

Remove four cotter pins (2).

1. Caliper body 2. Cotter pins 3. Caliper spring 4. Brake pad retainer spring

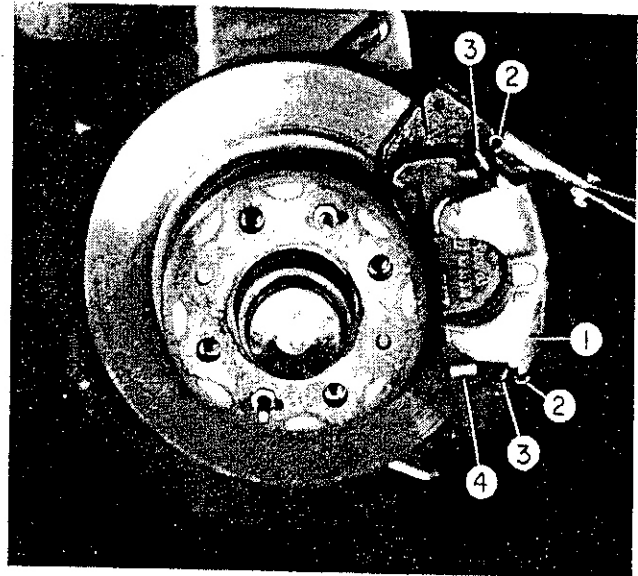

333

Remove two caliper locking blocks (3) with drift pin (4).

1. Caliper body 2. Support brackets 3. Caliper locking block 4. Drift pin

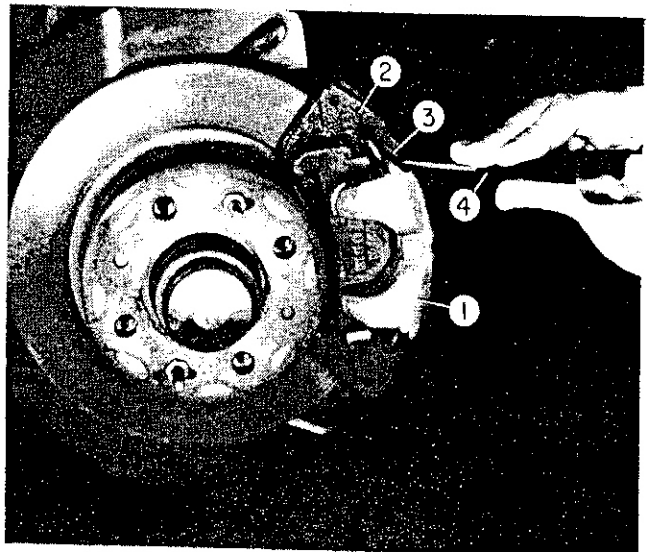

Separate caliper (1) from caliper support bracket (2).

To remove caliper for replacement or overhaul, disconnect brake line. Cap line to prevent dirt entry.

1. Caliper body 2. Caliper support bracket 3. Caliper spring

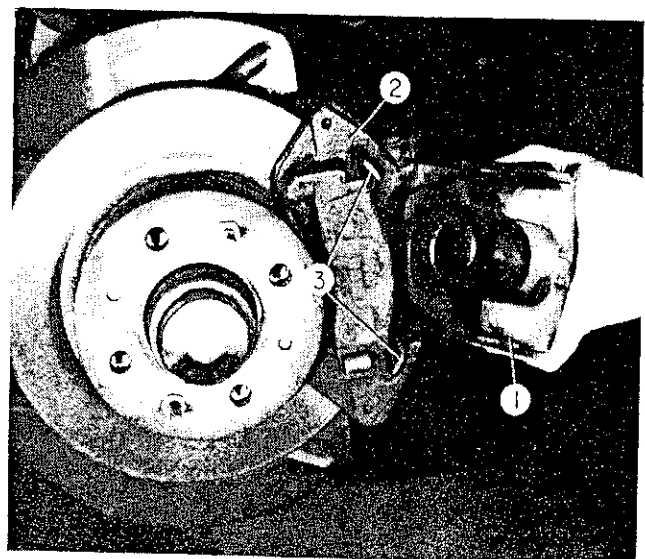

Remove two brake pads (1).

Inspect two retainer springs (2) and two caliper springs (3) for breakage. Replace if necessary.

1. Brake pad 2. Brake pad retainer spring 3. Caliper spring

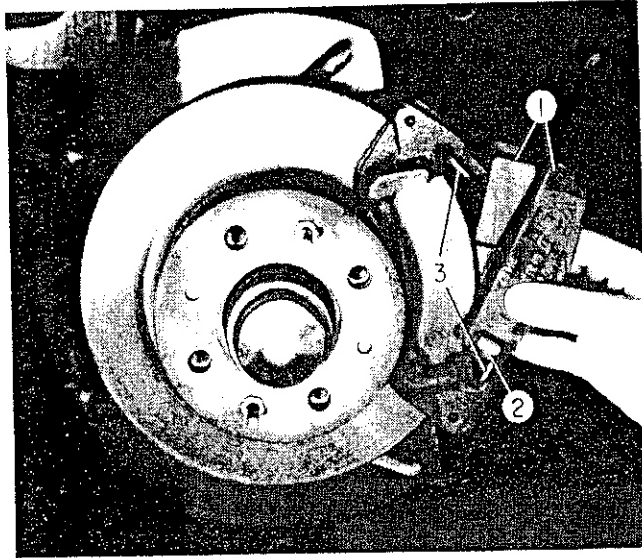

To remove caliper support bracket (1), remove two bolts at rear of bracket.

1. Caliper support bracket

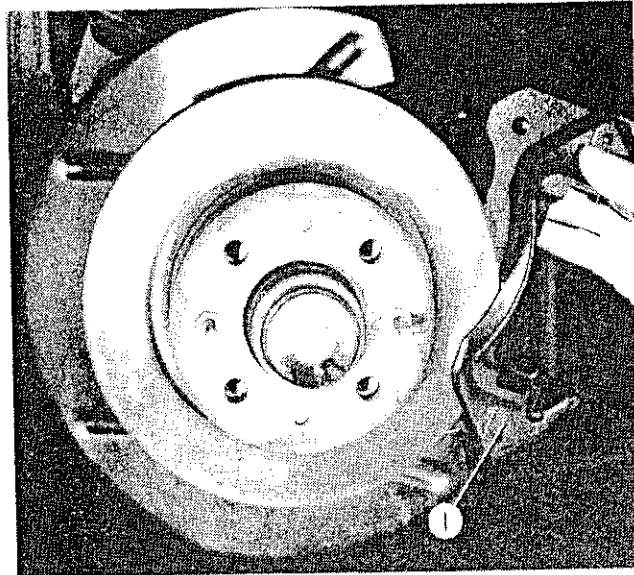

Check disc (1) for runout by placing a dial indicator (2) 0.08 in. (2 mm) from disc outer edge.

Runout must not be greater than 0.006 in. (0.15 mm), otherwise reface disc.

Thickness of disc after refacing must not be less than 0.368 in. (9.35 mm).

Minimum permissible thickness from wear is 0.354 in. (9 mm). Replace disc if less.

1. Brake disc 2. Dial indicator

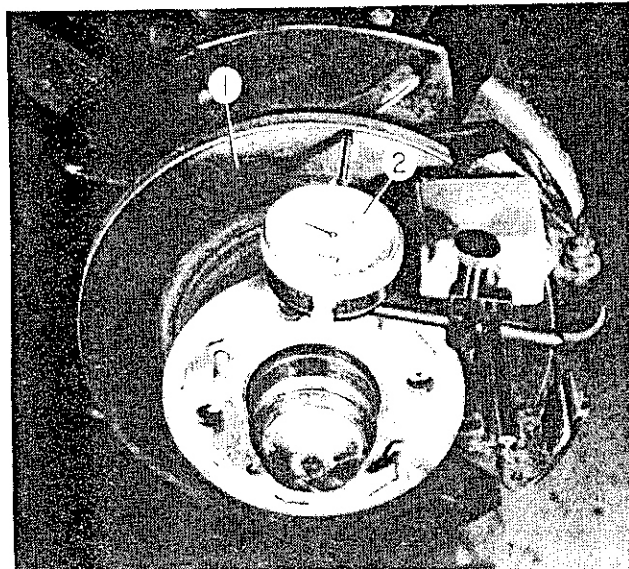

Installation is reverse of removal.

If new brake pads are being installed, it will be necessary to fully seat caliper piston (1) in bore in order to have installation clearance for calipers. Push in on center of piston with blunt object as shown (hammer handle, etc.) until piston bottoms out.

NOTE: Brake fluid will back up into master cylinder and may overflow.

1. Caliper piston

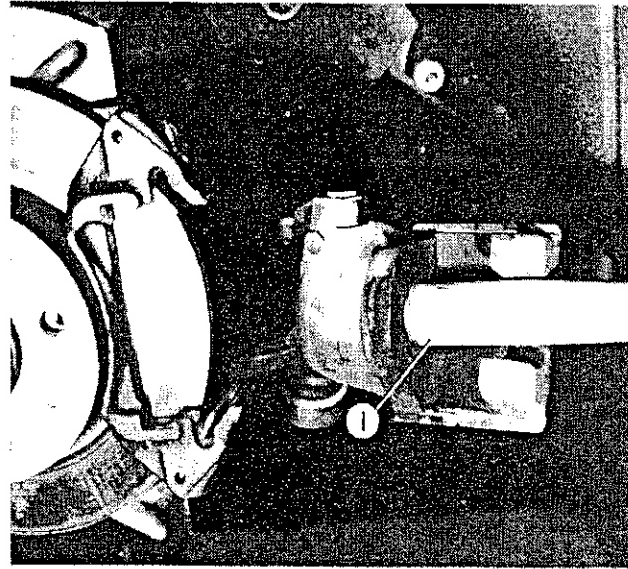

Torque caliper support bracket (4) bolts to 36 ft lb (5 kgm).

After installing caliper, install lower locking block first, then with hand pressure against front of caliper (1) force caliper back far enough to insert top locking block (2).

1. Caliper 2. Caliper locking block 3. Caliper spring 4. Caliper support bracket

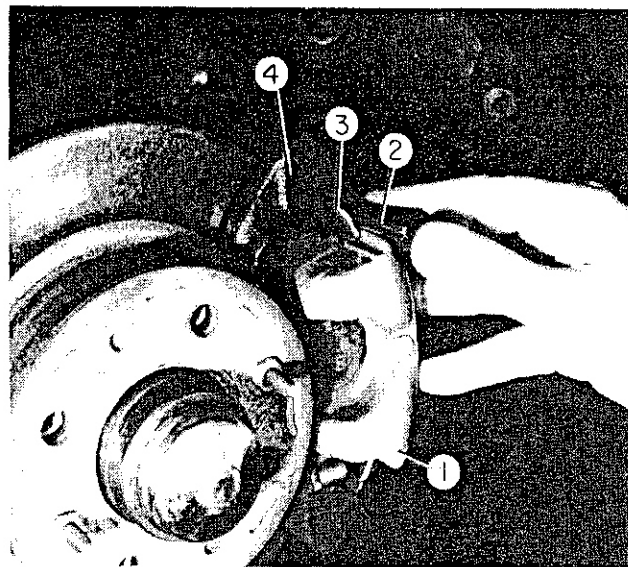

If caliper lines have been disconnected, bleed system (Refer to HYDRAULIC SYSTEM BLEEDING).

CAUTION: Before driving vehicle, pump brake pedal a few times to make sure caliper pistons are seated against pads and pedal is firm.

DISC

REMOVAL AND INSTALLATION

Remove caliper pads (Refer to CALIPER AND PADS REMOVAL AND INSTALLATION).

Remove two locating pin bolts (1). Remove plate (2) and disc (3).

Inspect disc for scoring or cracks. Discs can be refaced for scoring. Minimum thickness after refacing is 0.368 in. (9.35 mm). Replace disc if cracked.

Install in reverse order of removal.

1. Disc 2. Plate 3. Locking pin bolt

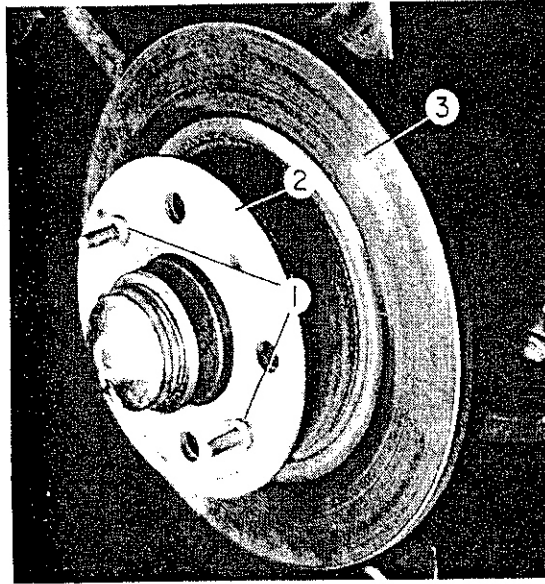

Rear Wheel Brakes

331.25

Page 33-23

CALIPER AND PADS

REMOVAL AND INSTALLATION

Remove wheels.

Remove four bolts and lockwashers to remove front section of backing plate (1).

Remove four cotter pins (2).

1. Backing plate 2. Cotter pin

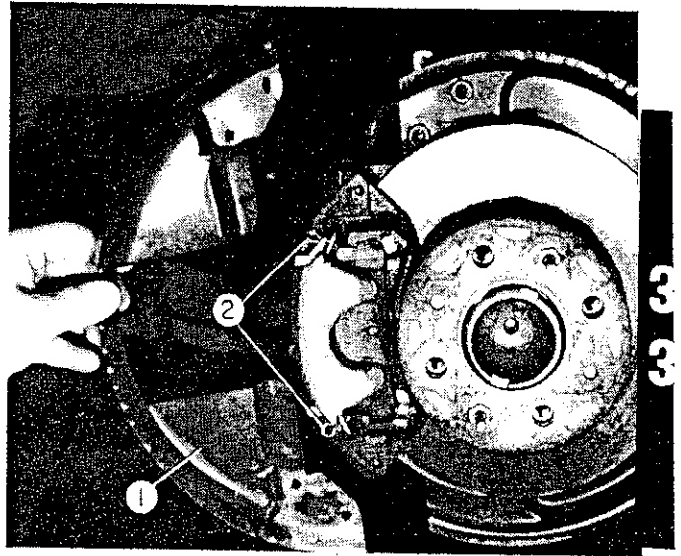

Remove two caliper locking blocks (1) with a drift pin (2).

1. Locking block 2. Drift pin 3. Caliper 4. Brake pad

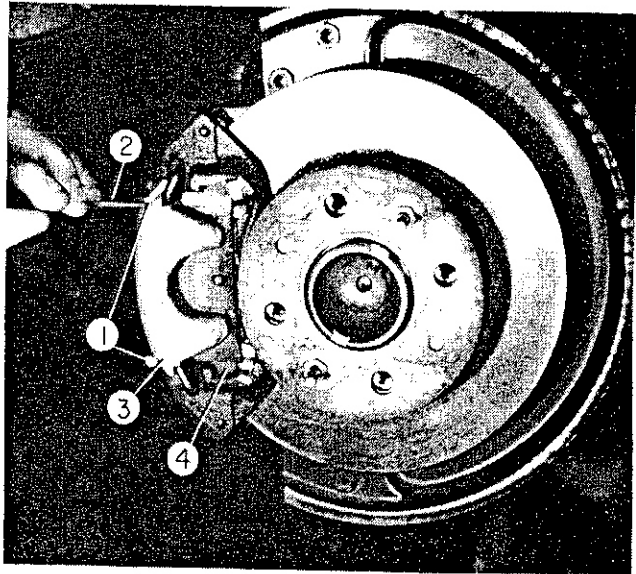

Separate caliper (1) from caliper support bracket (2).

To remove caliper for replacement or overhaul, disconnect brake line and hand brake cable from caliper. Cap brake line to prevent dirt entry.

1. Caliper 2. Caliper support bracket 3. Caliper spring

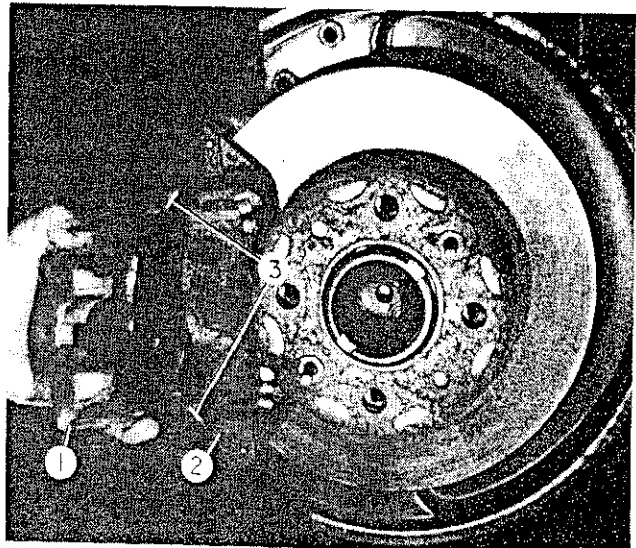

Remove two brake pads (1).

Inspect two retainer springs (2) and two caliper springs (3) for breakage. Replace if necessary.

1. Brake pad 2. Brake pad retainer spring 3. Caliper spring

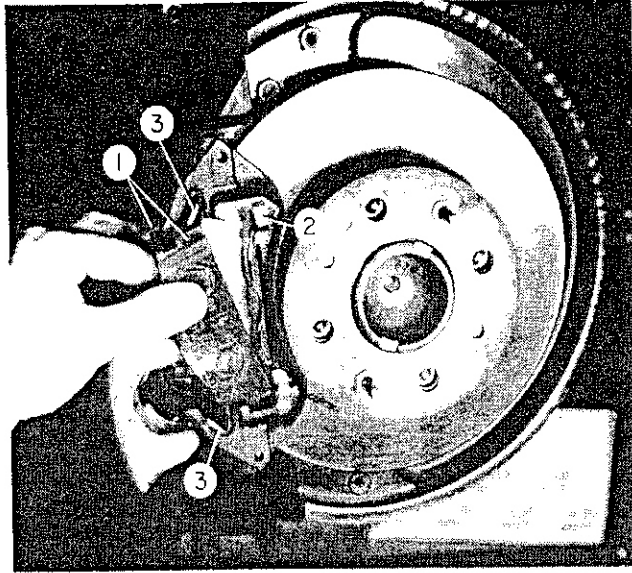

To remove caliper support bracket (1), remove two bolts at rear of bracket.

1. Caliper support bracket

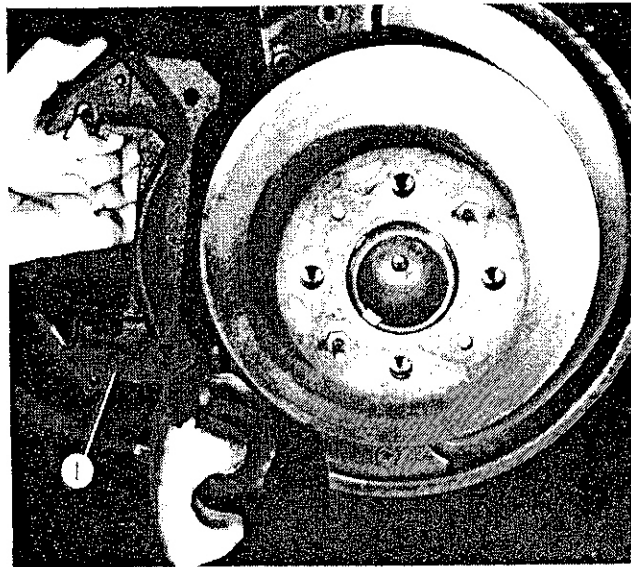

CAUTION: Before reassembling, make sure hand brake is completely off (cable slack). Make sure actuator lever is also completely bottomed to off position. If not done, hand brake operation will be ineffective.

Installation is reverse of removal.

If new brake pads are being installed, it will be necessary to fully seat caliper piston (1) in bore in order to have installation clearance for calipers. Push in on center of piston with blunt object (hammer handle, etc.) until piston bottoms out.

NOTE: Brake fluid will back up into master cylinder and may overflow.

CAUTION: Piston must be in position shown, with groove "A" on top, and slot parallel so that it aligns with knob "B" on brake pad (2).

1. Caliper piston 2. Brake pad

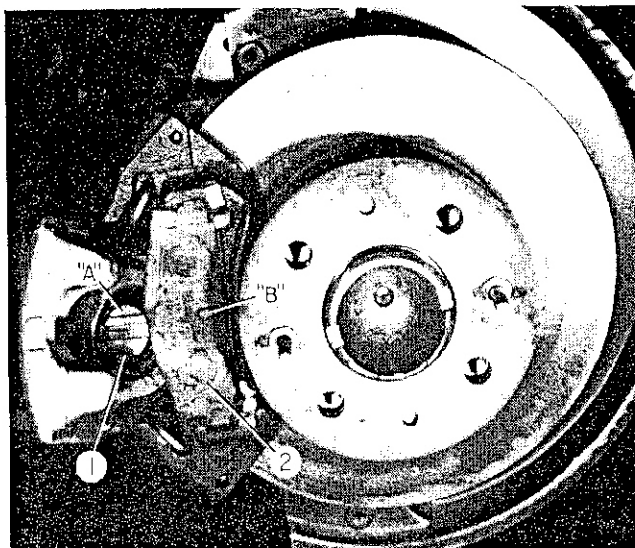

Rear Wheel Brakes

331.25

Page 33-25

Torque caliper support bracket (4) bolts to 36 ft lb (5 kgm).
After installing caliper, install lower locking block first, then with hand pressure against front of caliper (1) force caliper back far enough to insert top locking block (2).

1. Caliper 2. Caliper locking block 3. Caliper spring 4. Caliper support bracket

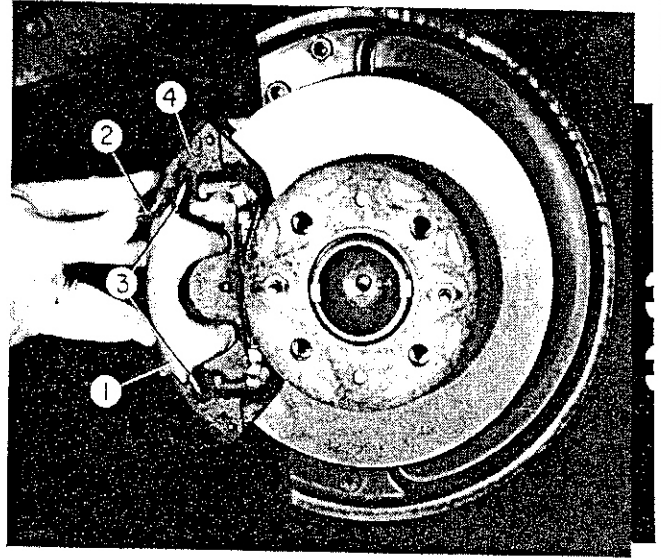

If caliper lines have been disconnected, bleed system (Refer to HYDRAULIC SYSTEM BLEEDING).

CAUTION: Before driving vehicle, pump brake pedal a few times to make sure caliper pistons are seated against pads and pedal is firm.

DISC**REMOVAL AND INSTALLATION**

Remove caliper and pads (Refer to CALIPER AND PADS REMOVAL AND INSTALLATION).

Remove two locating pin bolts (1). Remove plate (2) and disc (3).

Inspect discs for scoring or cracks. Discs can be refaced for scoring. Minimum thickness after refacing is 0.368 in. (9.35 mm). Replace disc if cracked.

Install in reverse order of removal.

1. Locking pin bolt 2. Plate 3. Disc

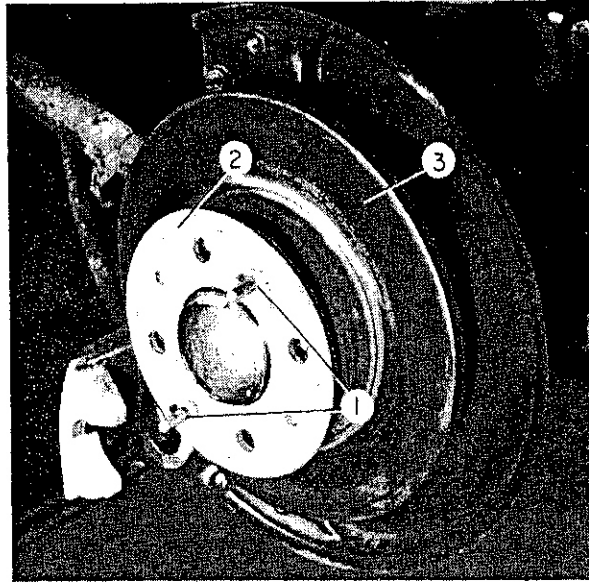

Check disc (1) for runout by placing a dial indicator (2) 0.08 in. (2 mm) from disc outer edge as shown. Runout must not be greater than 0.006 in. (0.15 mm), otherwise reface disc.

Thickness of disc after refacing must not be less than 0.372 in. (9.45 mm).

Minimum permissible thickness from wear is 0.354 in. (9 mm). Replace disc if less.

1. Brake disc 2. Dial indicator

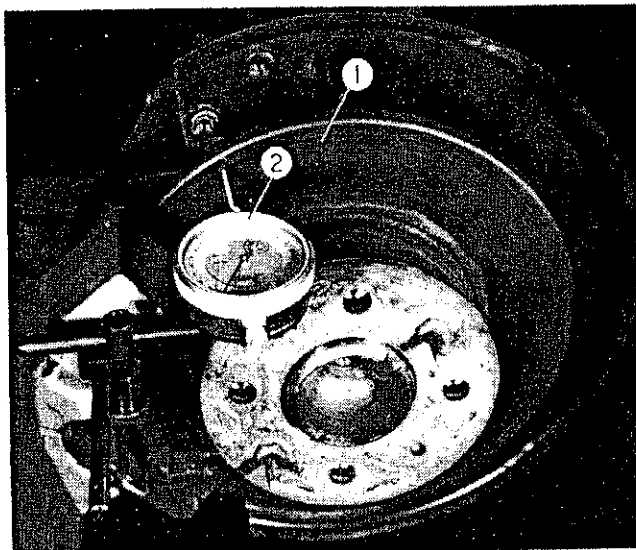

HAND BRAKE CABLE

REMOVAL AND INSTALLATION

Place hand brake in off position.

From under vehicle remove cotter pin (1) and washer to disconnect hand brake rod (2). Disconnect return springs (3) and remove spring equalizer (7).

Remove nuts (8) holding cable support brackets (9).

Pull ball end (10) of cable out of lever socket. To remove cable assembly from support (11), slide rubber boot (12) out of way and compress spring. Remove cable assembly (14) from support.

Install in reverse order of removal. Lubricate bearing surfaces with white grease.

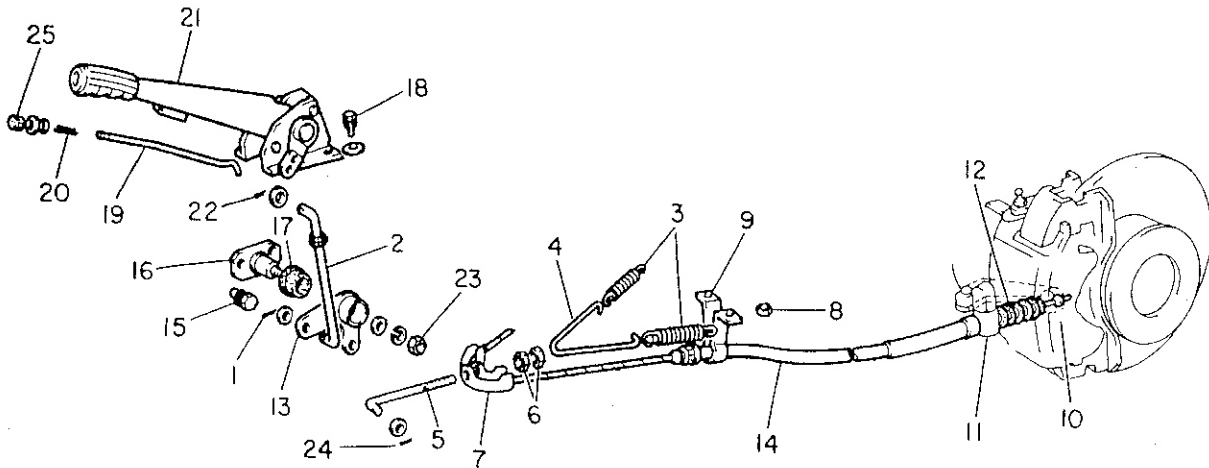

- | | | | | |
|-------------------|---------------------|--------------------|----------------------|----------------------|
| 1. Cotter pin | 6. Nut | 11. Support | 16. Mounting bracket | 21. Hand brake lever |
| 2. Hand brake rod | 7. Cable equalizer | 12. Rubber boot | 17. Bushing | 22. Cotter pin |
| 3. Return spring | 8. Nut | 13. Control arm | 18. Bolt | 23. Nut |
| 4. Spring holder | 9. Support | 14. Cable assembly | 19. Spring hook | 24. Cotter pin |
| 5. Cable rod | 10. Cable, ball end | 15. Bolt | 20. Spring | 25. Push button |

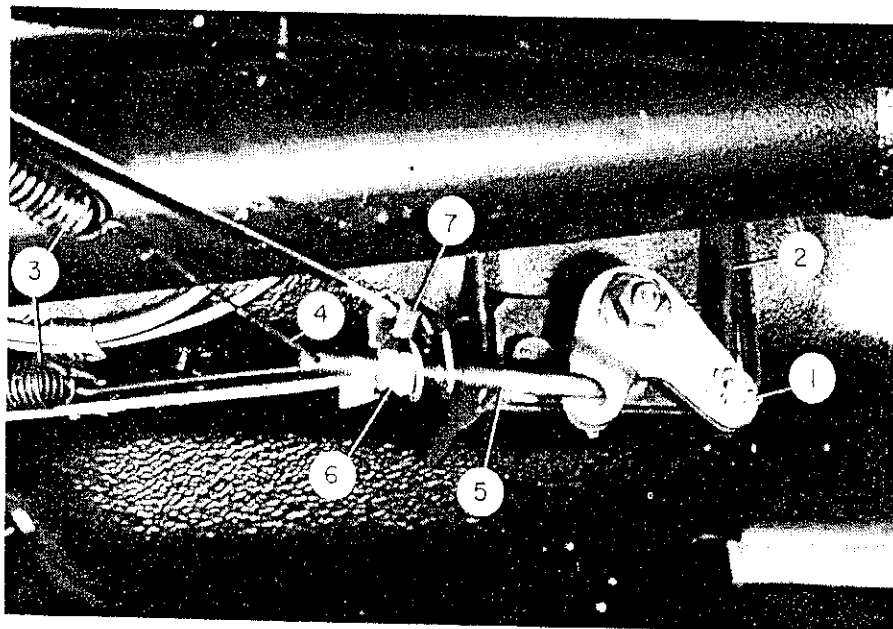

ADJUSTMENT

Whenever free travel is excessive or after replacing rear brakes or hand brake cable, adjust as follows:

NOTE: Brakes and hydraulic system must be in good condition for correct adjustment.

From under vehicle, loosen locknut (1). Back off locknut and adjusting nut (2) as far as possible.

From inside vehicle, pump brake pedal at least 6 times. Move hand brake lever up and down through full travel at least 6 times.

Place hand brake in off position, and then pull it up one or two clicks.

From under the vehicle, turn adjusting nut (2) until cable (3) is taut. Tighten locknut (1) against adjusting nut.

Hand brake is correctly adjusted when three clicks of hand brake will firmly actuate rear brakes.

If one or both rear brakes are locked with hand brake released check linkages and cables for free movement.

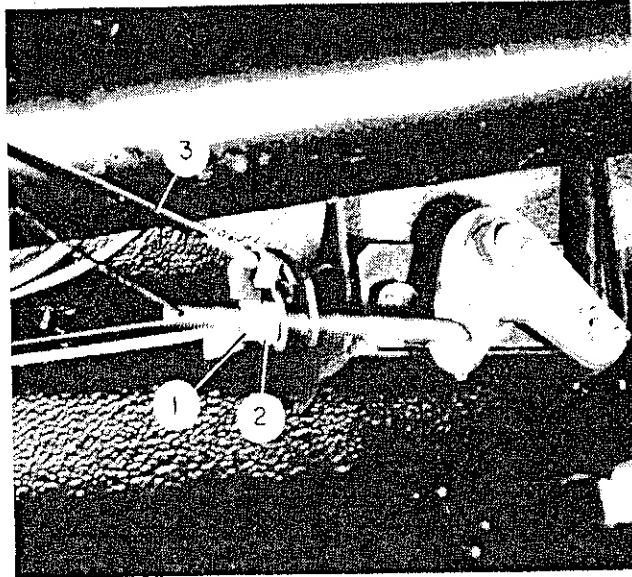

1. Locknut 2. Adjusting nut 3. Cable